

# **EDGE (with GSM) Measurement Guide**

## **Agilent Technologies E4406A VSA Series Transmitter Tester**



**Agilent Technologies**

**Manufacturing Part Number: E4406-90151**

**Printed in USA**

**July 2000**

© Copyright 1999 - 2000 Agilent Technologies, Inc.

The information contained in this document is subject to change without notice.

Agilent Technologies makes no warranty of any kind with regard to this material, including but not limited to, the implied warranties of merchantability and fitness for a particular purpose. Agilent Technologies shall not be liable for errors contained herein or for incidental or consequential damages in connection with the furnishing, performance, or use of this material.

## 1. Understanding EDGE

### (with GSM)

What Is EDGE (with GSM)?	8
Mobile Stations and Base Transceiver Stations	10
Uplink and Downlink	10
What Is an ARFCN?	11
What are Timeslots?	11
What Does the Agilent Technologies E4406A VSA Series Transmitter Tester Do?	12
Other Sources of Measurement Information	13
Instrument Updates at <a href="http://www.agilent.com/find/vsa">www.agilent.com/find/vsa</a>	13

## 2. Setting Up the EDGE

### (with GSM) Mode

Accessing the Mode	16
How to Make a Measurement	17
Changing the Mode Setup	18
Radio	18
Input	19
Trigger	21
Demod	23
Changing the Frequency Channel	24
EDGE (with GSM) Measurement Key Flow	26
Installing Optional Measurement Personalities	43
Available Personality Options	44
License Key Numbers	44
Installing a License Key Number	45
Using the Uninstall Key	46

## 3. Making EDGE (with GSM) Measurements

EDGE (with GSM) Measurements	48
Preparing for Measurements	49
Initial Setup	49
How to Make a Measurement	49
Measurement Control	50
Measurement Setup	51
EDGE (with GSM) Averaging	51
Trig Source	52
Burst Sync	53
Making the Transmit Power Measurement	54
Purpose	54
Measurement Method	54
Making the Measurement	55
Results	56
Changing the Measurement Setup	57
Troubleshooting Hints	58
Making the Power vs. Time Measurement	59
Purpose	59

---

# Contents

Measurement Method .....	59
Making the Measurement .....	60
Results .....	61
Changing the Measurement Setup .....	62
Power vs. Time Custom Masks .....	62
Changing the View .....	63
Changing the Display .....	63
Troubleshooting Hints .....	63
Making the Phase and Frequency Error Measurement .....	64
Purpose .....	64
Measurement Method .....	64
Making the Measurement .....	65
Results .....	66
Changing the Measurement Setup .....	69
Changing the View .....	69
Changing the Display .....	70
Troubleshooting Hints .....	70
Making the Output RF Spectrum Measurement .....	71
Purpose .....	71
Measurement Method .....	72
Making the Measurement .....	75
Results .....	76
Changing the Measurement Setup .....	77
Changing the View .....	82
Troubleshooting Hints .....	82
Making the Spectrum (Frequency Domain) Measurement .....	83
Purpose .....	83
Measurement Method .....	83
Making the Measurement .....	83
Results .....	84
Changing the Measurement Setup .....	85
Changing the View .....	89
Windows Available for Spectrum Measurements .....	89
Using the Markers .....	90
Band Power .....	91
Troubleshooting Hints .....	91
Making the Waveform (Time Domain) Measurement .....	92
Purpose .....	92
Measurement Method .....	92
Making the Measurement .....	92
Results .....	93
Changing the Measurement Setup .....	94
Changing the View .....	97
Windows Available for Waveform Measurements .....	97
Using the Markers .....	97
Band Power .....	98
Troubleshooting Hints .....	98
Making the Tx Band Spur Measurement .....	99
Purpose .....	99

---

# Contents

Measurement Method.....	99
Making the Measurement .....	100
Results .....	101
Changing the Measurement Setup .....	101
Changing the View .....	102
Troubleshooting Hints .....	102
Making the EDGE EVM Measurement .....	103
Purpose .....	103
Measurement Method.....	103
Making the Measurement .....	104
Results .....	104
Changing the Measurement Setup .....	105
Changing the View .....	106
Changing the Display .....	107
Troubleshooting Hints .....	109
Making the EDGE PvT Measurement .....	110
Purpose .....	110
Measurement Method.....	110
Making the Measurement .....	111
Results .....	112
Changing the Measurement Setup .....	113
Power vs. Time Custom Masks.....	113
Changing the View .....	114
Changing the Display .....	114
Troubleshooting Hints .....	114
Making the EDGE ORFS Measurement.....	115
Purpose .....	115
Measurement Method.....	115
Making the Measurement .....	119
Results .....	119
Changing the Measurement Setup .....	120
Changing the View .....	124
Troubleshooting Hints .....	124





## What Is EDGE (with GSM)?

The Global System for Mobile communication (GSM) digital communications standard defines a voice and data over-air interface between a mobile radio and the system infrastructure. This standard was designed as the basis for a radio communications system. A base station control center (BSC) is linked to multiple base transceiver station (BTS) sites which provide the required coverage.

EDGE (Enhanced Data Rates for GSM Evolution) enhances the GSM standard with a new modulation format ( $3\pi/8$  8PSK) and filtering designed to provide higher data rates in the same spectrum. EDGE has also been adopted as the basis for IS-136HS (NADC).

GSM 900, GSM 450, GSM 480, GSM 850, DCS 1800, and PCS 1900 are GSM-defined frequency bands. The term GSM 900 is used for any EDGE (with GSM) system operating in the 900 MHz band, which includes P-GSM, E-GSM, and R-GSM. Primary (or standard) GSM 900 band (P-GSM) is the original GSM band. Extended GSM 900 band (E-GSM) includes all the P-GSM band plus an additional 50 channels. Railway GSM 900 band (R-GSM) includes all the E-GSM band plus additional channels.

DCS 1800 is an adaptation of GSM 900, created to allow for smaller cell sizes for higher system capacity. PCS 1900 is intended to be identical to DCS 1800 except for frequency allocation and power levels. The term GSM 1800 is sometimes used for DCS 1800, and the term GSM 1900 is sometimes used for PCS 1900. For specifics on the bands, refer to Table 1-1.

The GSM digital communications standard employs an 8:1 Time Division Multiple Access (TDMA) allowing eight channels to use one carrier frequency simultaneously. The 270.833 kbits/second raw bit rate is modulated on the RF carrier using Gaussian Minimum Shift Keying (GMSK).

The standard includes multiple traffic channels (TCH), a control channel (CCH), and a broadcast control channel (BCCH). The GSM specification defines a channel spacing of 200 kHz.



**Table 1-1 EDGE (with GSM) Band Data**

	<b>P-GSM (GSM 900)</b>	<b>E-GSM (GSM 900)</b>	<b>R-GSM (GSM 900)</b>	<b>DCS 1800 (GSM 1800)</b>	<b>PCS 1900 (GSM 1900)</b>	<b>GSM 450</b>	<b>GSM 480</b>	<b>GSM 850</b>
<b>Uplink (MS Transmit)</b>	890 to 915 MHz	880 to 915 MHz	876 to 915 MHz	1710 to 1785 MHz	1850 to 1910 MHz	450.4 to 457.6 MHz	478.8 to 486 MHz	824 to 849 MHz
<b>Downlink (BTS Transmit)</b>	935 to 960 MHz	925 to 960 MHz	921 to 960 MHz	1805 to 1880 MHz	1930 to 1990 MHz	460.4 to 467.6 MHz	488.8 to 496 MHz	869 to 894 MHz
<b>Range (ARFCN)</b>	1 to 124	0 to 124 and 975 to 1023	1 to 124 and 955 to 1023	512 to 885	512 to 810	259 to 293	306 to 340	128 to 251
<b>TX/RX Spacing (Freq.)</b>	45 MHz	45 MHz	45 MHz	95 MHz	80 MHz	45 MHz	45 MHz	45 MHz
<b>TX/RX Spacing (Time)</b>	3 timeslots	3 timeslots	3 timeslots	3 timeslots	3 timeslots	3 timeslots	3 timeslots	3 timeslots
<b>Modulation Data Rate</b>								
<b>GMSK (kbits/s):</b>	270.833	270.833	270.833	270.833	270.833	270.833	270.833	270.833
<b>8PSK (kbits/s):</b>	812.499	812.499	812.499	812.499	812.499	812.499	812.499	812.499
<b>Frame Period</b>	4.615 ms	4.615 ms	4.615 ms	4.615 ms	4.615 ms	4.615 ms	4.615 ms	4.615 ms
<b>Timeslot Period</b>	576.9 $\mu$ s	576.9 $\mu$ s	576.9 $\mu$ s	576.9 $\mu$ s	576.9 $\mu$ s	576.9 $\mu$ s	576.9 $\mu$ s	576.9 $\mu$ s
<b>Bit Period</b>	3.692 $\mu$ s	3.692 $\mu$ s	3.692 $\mu$ s	3.692 $\mu$ s	3.692 $\mu$ s	3.692 $\mu$ s	3.692 $\mu$ s	3.692 $\mu$ s
<b>Modulation</b>	0.3 GMSK 3 $\pi$ /8 8PSK	0.3 GMSK 3 $\pi$ /8 8PSK	0.3 GMSK 3 $\pi$ /8 8PSK	0.3 GMSK 3 $\pi$ /8 8PSK	0.3 GMSK 3 $\pi$ /8 8PSK	0.3 GMSK 3 $\pi$ /8 8PSK	0.3 GMSK 3 $\pi$ /8 8PSK	0.3 GMSK 3 $\pi$ /8 8PSK
<b>Channel Spacing</b>	200 kHz	200 kHz	200 kHz	200 kHz	200 kHz	200 kHz	200 kHz	200 kHz
<b>TDMA Mux</b>	8	8	8	8	8	8	8	8
<b>MS Max Power</b>	20 W (8 W is max in use)	20 W	20 W	20 W	20 W	20 W	20 W	20 W
<b>MS Min Power</b>	13 dBm	5 dBm	0 dBm	0 dBm	0 dBm	5 dBm	5 dBm	5 dBm
<b>MS Power Control Steps</b>	0 to 15	2 to 19	2 to 19	0 to 15 29,30,31	0 to 15 30, 31,	2 to 19	2 to 19	2 to 19
<b>Voice Coder Bit Rate</b>	13 kbits/s	13 kbits/s, 5.6 kbits/s	13 kbits/s	13 kbits/s	13 kbits/s	13 kbits/s	13 kbits/s	13 kbits/s

The GSM framing structure is based on a hierarchical system consisting of timeslots, TDMA frames, multiframes, superframes, and hyperframes. One timeslot is 156.25 (157) bit periods including tail, training sequence, encryption, guard time, and data bits. Eight of these timeslots make up one TDMA frame. Either 26 or 51 TDMA frames make up one multiframe. Frames 13 and 26 in the 26 frame multiframe are dedicated to control channel signaling.

EDGE employs the same symbol rate and frame structure as GSM.

EDGE and GSM signals can be transmitted on the same frequency, occupying different timeslots, and both use existing GSM equipment. Due to the similarity between the formats, the transmitter measurements are the same, with the addition of the following three EDGE-specific measurements:

- EDGE EVM - Provides a measure of modulation accuracy. EDGE 8PSK modulation pattern uses a rotation of  $3\pi/8$  radians to avoid zero crossing, thus affording some margin of linearity relief for amplifier performance. It is substantially more demanding than GSM modulation (GMSK), and EDGE EVM testing is necessary to reveal performance shortcomings.
- EDGE PvT - Verifies that the transmitter output power has the correct amplitude, shape, and timing for the EDGE format.
- EDGE ORFS - Verifies that the RF carrier is contained within the designated 200 kHz channel.

## **Mobile Stations and Base Transceiver Stations**

The cellular system includes the following:

- base transceiver stations, referred to as BTS  
(frequency ranges dependent on the standard; refer to Table 1-1)
- mobile stations, referred to as MS  
(frequency ranges dependent on the standard; refer to Table 1-1)

## **Uplink and Downlink**

Uplink is defined as the path from the mobile station to the base transceiver station. Downlink is the path from the base transceiver station to the mobile station.

## **What Is an ARFCN?**

An ARFCN is the Absolute Radio Frequency Channel Number used in the EDGE (with GSM) system. Each RF channel is shared by up to eight mobile stations using Time Division Multiple Access (TDMA). The ARFCN is an integer (in a range dependent on the chosen standard, refer to Table 1-1) which designates the carrier frequency.

## **What are Timeslots?**

EDGE (with GSM) utilizes Time Division Multiple Access (TDMA) with eight time slots per RF channel which allows eight users to use a single carrier frequency simultaneously. Users avoid one another by transmitting in series. The eight users can transmit once every 4.62 ms for 1 timeslot which is 577  $\mu$ s long. The eight user timeslots are numbered from 0 to 7.

Typically, each 577  $\mu$ s timeslot has a length of 156.25 bit periods, which consists of 148 data bits and 8.25 guard bits. The 4.62 ms required to cycle through eight timeslots is called a frame. In a TDMA system, the shape of each transmitted burst must be controlled carefully to avoid over-lapping bursts in time.

## **What Does the Agilent Technologies E4406A VSA Series Transmitter Tester Do?**

The E4406A VSA Series Transmitter Tester makes measurements that conform to the GSM 5.04, 5.05, 11.10, 11.21, and ANSI J-STD-007 specifications.

These documents define complex, multi-part measurements used to maintain an interference-free environment. For example, the documents include measuring the power of a carrier. The E4406A automatically makes these measurements using the measurement methods and limits defined in the standards. The detailed results displayed by the measurements allow you to analyze EDGE (with GSM) system performance. You may alter the measurement parameters for specialized analysis.

This instrument was primarily developed for making measurements on digital transmitter carriers. These measurements can help determine if a GSM transmitter is working correctly. The E4406A is capable of measuring the continuous carrier of a base station transmitter.

For infrastructure test, the instrument will test base station transmitters in a non-interfering manner by means of a coupler or power splitter.

This instrument makes the following measurements:

- Transmit Power
- Power versus Time
- Phase and Frequency Error
- Output RF Spectrum
- Spectrum (Frequency Domain)
- Waveform (Time Domain)
- Tx Band Spur
- EDGE EVM
- EDGE PvT
- EDGE ORFS

## **Other Sources of Measurement Information**

Additional measurement application information is available through your local Agilent Technologies sales and service office. The following application notes treat digital communications measurements in much greater detail than discussed in this measurement guide.

- Application Note 1298  
Digital Modulation in Communications Systems - An Introduction  
part number 5965-7160E
- Application Note 1312  
Understanding GSM Transmitter Measurements for Base  
Transceiver Stations and Mobile Stations  
part number 5966-2833E

### **Instrument Updates at [www.agilent.com/find/vsa](http://www.agilent.com/find/vsa)**

This web location can be used to access the latest information about the transmitter tester.





## Accessing the Mode

At initial power up, the transmitter tester will come up in the Basic mode, with the Spectrum (Frequency Domain) measurement selected and the Measure menu displayed.

To access the EDGE (with GSM) measurement personality, press the **MODE** key and select the **EDGE w/GSM** key.

If you want to set the mode to a known factory default state, press **Preset**. This will preset the mode setup and all of the measurements to the factory default parameters.

---

### NOTE

Note that pressing the **Preset** key does not switch instrument modes.

You may want to install a new personality, reinstall a personality that you have previously uninstalled, or uninstall a personality option. Instructions can be found in “Installing Optional Measurement Personalities” later in this section.



---

## How to Make a Measurement

Follow the three-step process shown in the table below:

<b>Step</b>	<b>Primary Key</b>	<b>Setup Keys</b>	<b>Related Keys</b>
1. Select & setup a mode	Mode	Mode Setup, Input, Frequency Channel	System
2. Select & setup a measurement	Measure	Meas Setup	Meas Control, Restart
3. Select & setup view	View/Trace	Span X Scale, Amplitude Y Scale, Display, Next Window, Zoom	File, Save, Print, Print Setup, Marker, Search

## Changing the Mode Setup

Numerous settings can be changed at the mode level by pressing the **Mode Setup** key. This will access a menu with the selections listed below. These settings affect all the measurements in the GSM mode.

### Radio

The **Radio** key accesses a menu to select:

- **Band** - Select the GSM band (P-GSM, E-GSM, R-GSM, GSM 450, GSM 480, GSM 850, DCS 1800, or PCS 1900). Refer to the table in the previous section for GSM band data.
- **Device** - Select the device to test BTS (Base Transceiver Station) or MS (Mobile Station).
- **BTS Type** - Select the type of BTS (Base Transceiver Station) to be tested (Normal, Micro, or Pico).
- **Freq Hopping** - Turn frequency hopping on or off. If frequency hopping is turned on, the instrument will ignore the bursts when the frequency is hopped off the selected channel frequency. Thus only valid data is included in the results. Only the Power vs. Time, and the Phase and Frequency Error measurements can be made on hopping GSM signals.
- **Carrier** - Select the type of carrier to measure (Burst or Continuous).

Radio Default Settings	
Band	E-GSM
Device	BTS
BTS Type	Normal
Freq Hopping	Off
Carrier	Burst

## Input

The **Input** key accesses a menu to select the following. (You can also access this menu from the front-panel key **Input**.)

- **Input Port** - Choose between **RF**, **I/Q**, **I Only**, **50 MHz Ref**, and **IF Align**.
- **RF Input Range** - To set the RF input range, choose **Auto** or **Manual**. If **Auto** is chosen, the instrument automatically sets the attenuator based on the power level of the carrier (where the instrument is tuned). If there are multiple carriers present, the total power might overdrive the front end. In this case you need to set the **RF Input Range** to **Manual** and enter the expected **Max Total Pwr**. **Manual** is also used if you want to hold the input attenuation constant (for the best relative power accuracy). For single carriers it is generally recommended to set the **RF Input Range** to **Auto**.
- **Max Total Pwr** - To set the maximum total power at the UUT (Unit Under Test). This is the maximum expected value of the mean carrier power referenced to the output of the UUT (may include multiple carriers). The **Max Total Pwr** setting is coupled to the **Input Atten** setting. If **RF Input Range** is set to **Auto**, and **Max Total Pwr** is changed, **RF Input Range** is switched to **Manual**.
- **Input Atten** - To set the input attenuator setting. The **Input Atten** setting is coupled to the **Max Total Pwr** setting. The **Input Atten** key reads out the actual hardware value that will be used for the current measurement. If more than one input attenuator value is used in a single measurement, the value used at the carrier frequency will be displayed. If **RF Input Range** is set to **Auto**, and **Input Atten** is changed, **RF Input Range** is switched to **Manual**.

---

NOTE

The **Max Total Pwr** and **Input Atten** settings are coupled together. When you switch to a different measurement, the **Max Total Pwr** is kept constant, but the **Input Atten** may change if the two measurements have different mixer margins. Thus, you can directly set the transmitter tester input attenuation, or you can set it indirectly by specifying the maximum expected power at the UUT (**Max Total Pwr** setting).

---

- **Ext Atten** - To enter the external attenuator setting for either a **BTS** or **MS**. This will allow the instrument to display the measurement results referred to the output of the UUT (Unit Under Test).

- **IF Align Signal** - This key has effect only when **Input Port** is set to **IF Align**. When **IF Align** is activated, the RF path is switched to bring in the same alignment signal that is automatically switched in to perform many alignments. This selection will allow manual adjustment of the alignment signal for diagnostic purposes:
  - **Signal Rate** - The signal is modulated by a digital sequence that can be set to 1 of 13 positions (rate 0 through 12) to cause the comb spacing (or pulse timing) of the alignment signal to widen or narrow. The key reports the comb spacing for a given rate (0 to 12) in “kHz”.
  - **Signal Amptd** - This is the DAC control that changes the amplitude of the signal. It is a 12 bit (0 to 4095) DAC. A higher DAC number will raise the signal amplitude.
  - **Signal Type** - This can be **CW** (a tone that appears in the center of the IF), **Comb**, or **Pulse**.

<b>Input Default Settings</b>	
Input Port	RF
RF Input Range	Auto
Max Total Power	-15.00 dBm
Input Atten	0.00 dB
Ext Atten MS	0.00 dB
Ext Atten BTS	0.00 dB
IF Align Signal Rate	0 (= 468.75 kHz)
IF Align Signal Amptd	DAC 500
IF Align Signal Type	CW

## Trigger

The **Trigger** key accesses the mode setup menu for the following trigger source menus:

- **Free Run (Immediate)**
- **RF Burst**
- **Video (IF Envlp)**
- **Ext Front**
- **Ext Rear**
- **Frame**

Pressing one of the trigger source menu keys will access the trigger mode setup menu. This menu is used to set the **Delay**, **Level**, and **Slope** for each trigger source. Note that the actual trigger source is selected separately for each measurement (under the **Meas Setup** key).

**Delay** - For trigger delay use positive values. For pre-trigger use negative values.

**Level** - For the **RF Burst** selection, the level is relative to the peak level of the RF signal. For the **Video** selection, the level is the value, in dBm at the RF input, that will cause the trigger. For the **Ext Front** and **Ext Rear** selections, the level range is -5 to +5 volts.

**Slope Pos Neg** - Choose to trigger off of the leading edge (**Pos**) or the trailing edge (**Neg**) of the burst.

Other keys accessed under the **Trigger** key:

- **Trig Holdoff** - Sets the period of time before the next trigger can occur.
- **Auto Trig** - Acts as a trigger timeout. If no trigger occurs by the specified time, a trigger is automatically generated.
- **Frame Timer** - Accesses the menu to manually control the frame timer:

**Period** - Sets the period of the frame clock.

**Offset** - Sets a one-time phase adjustment of the frame clock.

**Reset Offset** - Resets the display of offset key to 0.

**Sync Source** - Selects the source used to sync the frame timer (**Ext Front**, **Ext Rear**, or **Off**).

- **RF Sync Delay** - In measurements that detect the GSM “T0”, **RF Sync Delay** adjusts the “T0” point. This adjustment does not apply if the **Burst Sync** key is set to **None**, or if it is set to **Training Seq** in the Phase and Frequency Error measurement. The “T0” point is defined as the time point of the transition from bit 13 to bit 14 of the midamble training sequence for a given time slot.
- **Burst Search Threshold** - Sets the threshold level used in the search for EDGE (with GSM) bursts after data is acquired. This is a relative level based on the peak “on” power.

<b>Trigger Default Settings</b>	
<b>RF Burst</b>	
Delay	0.000 s
Peak Level	-20.00 dB
Slope	Pos
<b>Video</b>	
Delay	0.000 s
Level	-6.00 dBm
Slope	Pos
<b>Ext Front</b>	
Delay	0.000 s
Level	2.00 V
Slope	Pos
<b>Ext Rear</b>	
Delay	0.000 s
Level	2.00 V
Slope	Pos
Trig Holdoff	0.000 s
Auto Trig	100.0 ms Off
<b>Frame Timer</b>	
Period	4.615383 ms
Offset	0.000 s
Reset Offset	Display
Sync Source	Off
RF Sync Delay	0.000 s
Burst Search Threshold	-40.00 dB

## Demod

- **Burst Align** - Select the burst alignment between:

**EDGE (with GSM)**- Uses the burst alignment as defined in the EDGE (with GSM) specifications.

**1/2 Bit Offset** - Shifts the burst alignment by 1/2 bit. This selection applies to the Power vs. Time and the Phase and Frequency Error measurements.

<b>Demod Default Settings</b>	
Demod Burst Align	EDGE (with GSM)

## Changing the Frequency Channel

After selecting the desired mode setup, you will need to select the desired ARFCN, center frequency, BMT frequency, burst type, and TSC (Training Sequence Code). The selections made here will apply to all measurements in the mode. Press the **Frequency Channel** key to access the following menu:

- ARFCN** Allows you to select the desired RF channel to be measured. Refer to the table in the previous section for the ARFCN range for a specific GSM band.
- Center Freq** This is the current instrument center frequency. Use this key to input a frequency that corresponds to the desired RF channel to be measured.
- BMT Freq** Allows you to select the Bottom, Middle, or Top frequencies of the selected radio band to be measured. This will automatically select a specific center frequency and ARFCN. Refer to the following table.

Band	Tx Band Edge (MHz)		BOTTOM		MIDDLE		TOP	
	Low	High	Freq (MHz)	ARFCN	Freq (MHz)	ARFCN	Freq (MHz)	ARFCN
P-GSM	935	960	935.200	1	947.600	63	959.800	124
E-GSM	925	960	925.200	975	942.600	38	959.800	124
R-GSM	921	960	921.200	955	940.600	28	959.800	124
DCS 1800	1805	1880	1805.20	512	1842.60	699	1879.80	885
PCS 1900	1930	1990	1930.20	512	1960.00	661	1989.80	810
GSM 450	460.4	467.6	460.600	259	464.000	276	467.400	293
GSM 480	488.8	496.0	489.000	306	492.400	323	495.800	340
GSM 850	869	894	869.200	128	881.600	190	893.800	251



- Timeslot** Allows you to select the timeslot to be measured. Timeslot numbers in the range of 0 to 7 can be selected. Selection of the Timeslot is based on the position on the screen—that is Timeslot 0 is defined to be at the start of the data, and the data is divided into 8 timeslots (0 to 7). This key will be unavailable (grayed out) if a burst type other than **Normal** is selected.
- Burst Type** Choose an EDGE (with GSM) burst type from the following selections:
- **Normal (TCH & CCH)** - Burst length = 142 symbols
  - **Sync (SCH)** - Burst length = 142 symbols
  - **Access (RACH)** - Burst length = 88 symbols
- TSC** Allows you to select the Training Sequence Code that determines which burst is to be measured. This key will be unavailable (grayed out) if a burst type other than **Normal** is selected, indicating the standard TSC is used corresponding to the burst type.
- **Auto** - In auto, the measurement is made on the first burst found to have any one of the valid TSCs in the range of 0 to 7. The measurement may be made on various timeslots if more than one timeslot has one of the 8 valid TSCs.
  - **Man** - In manual, the measurement is made on the first burst found to have the selected TSC. TSC numbers in the range of 0 to 7 can be selected. The measurement may be made on various timeslots if more than one timeslot has this same TSC.

When the EDGE (with GSM) mode is selected, the instrument will default to the following settings.

Function	Factory Default Setting
ARFCN	>251
Center Frequency	942.600 MHz
Timeslot	0 Off
Burst Type	Normal (TCH & CCH)
TSC (Std)	0 Auto

## EDGE (with GSM) Measurement Key Flow

The key flow diagrams, shown in a hierarchical manner on the following pages, will help the user to grasp the overall functional relationships for the front-panel keys and the softkeys displayed at the extreme right side of the screen. The diagrams are:

- “Mode Setup / Frequency Channel Key Flow” on page 28
- “Transmit Power Measurement Key Flow” on page 29
- “Power vs. Time Measurement Key Flow” on page 30
- “Phase and Frequency Error Measurement Key Flow” on page 31
- “Output RF Spectrum Measurement Key Flow” on page 32
- “Spectrum (Freq Domain) Measurement Key Flow (1 of 3)” on page 33
- “Waveform (Time Domain) Measurement Key Flow (1 of 2)” on page 36
- “Tx Band Spur Measurement Key Flow” on page 38
- “EDGE EVM Measurement Key Flow” on page 39
- “EDGE PvT Measurement Key Flow” on page 40
- “EDGE ORFS Measurement Key Flow (1 of 2)” on page 41

Use these flow diagrams as follows:

- There are some basic conventions:

 View/Trace

An oval represents one of the front-panel keys.

 QPSK EVM

This box represents one of the softkeys displayed.

<for EVM>

This represents an explanatory description on its specific key.

 Avg Number 10 On|Off

This box represents one of the default condition softkeys displayed. Default conditions are shown as much as possible with underlined parameters or values displayed on those softkey labels.

- Follow the measurement diagram from left to right and top to bottom.
- A single softkey may allow multiple choices. For example; the **Device** softkey reveals two choices, **BTS** or **MS**. The underlined choice is the current state of the instrument. To change choices, press the softkey one time.
- When entering a numeric value of **Frequency**, for example, use the numeric keypad and terminate the entry with the appropriate unit selection from the softkeys displayed.

- When entering a numeric value of **Slot (Std)**, for example, use the numeric keypad and terminate with the **Enter** front-panel key.
- Instead of using the numeric keypad to enter a value, it may be easier to use the RPG knob or **Up/Down** keys.

**Figure 2-1 Mode Setup / Frequency Channel Key Flow**

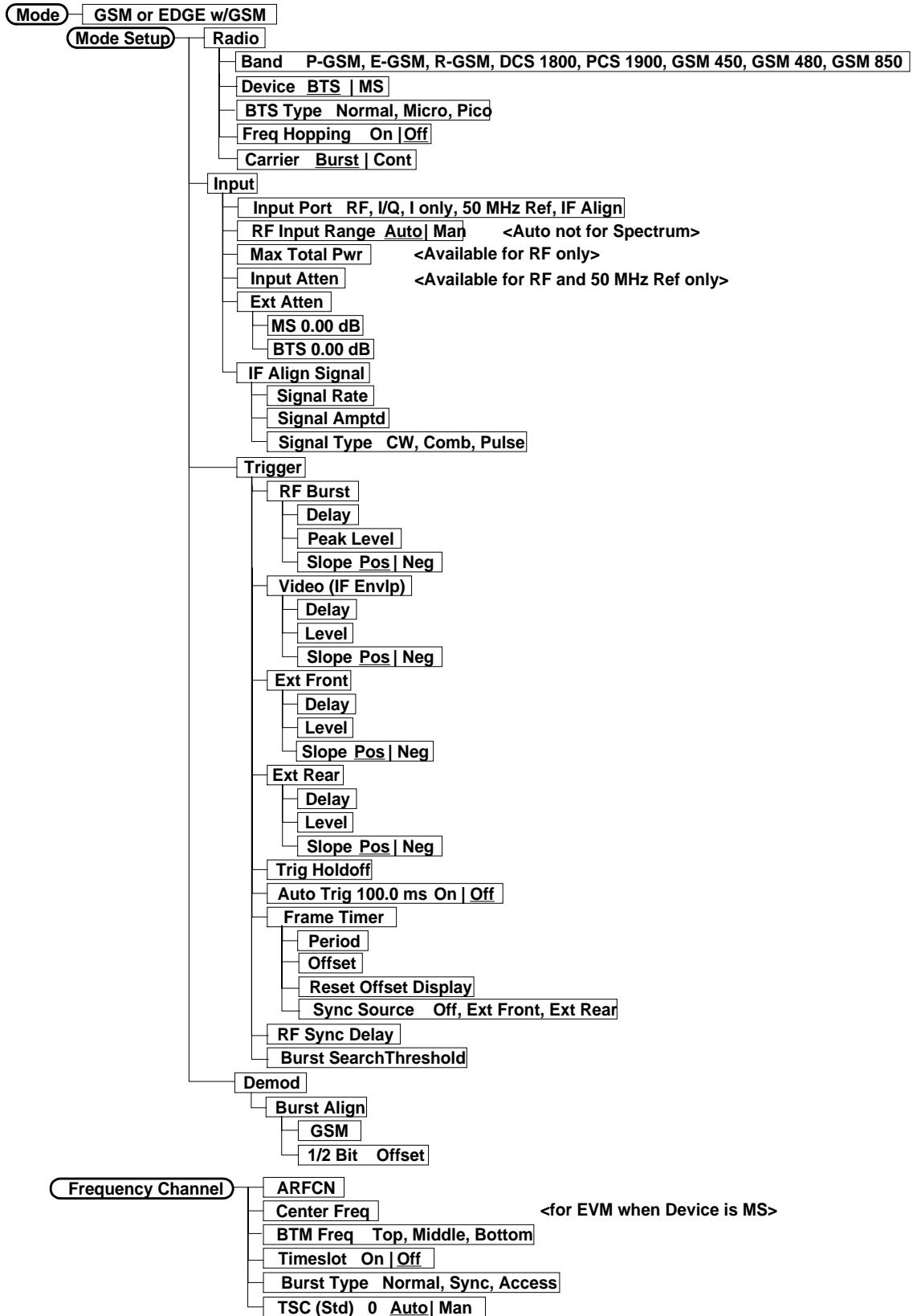
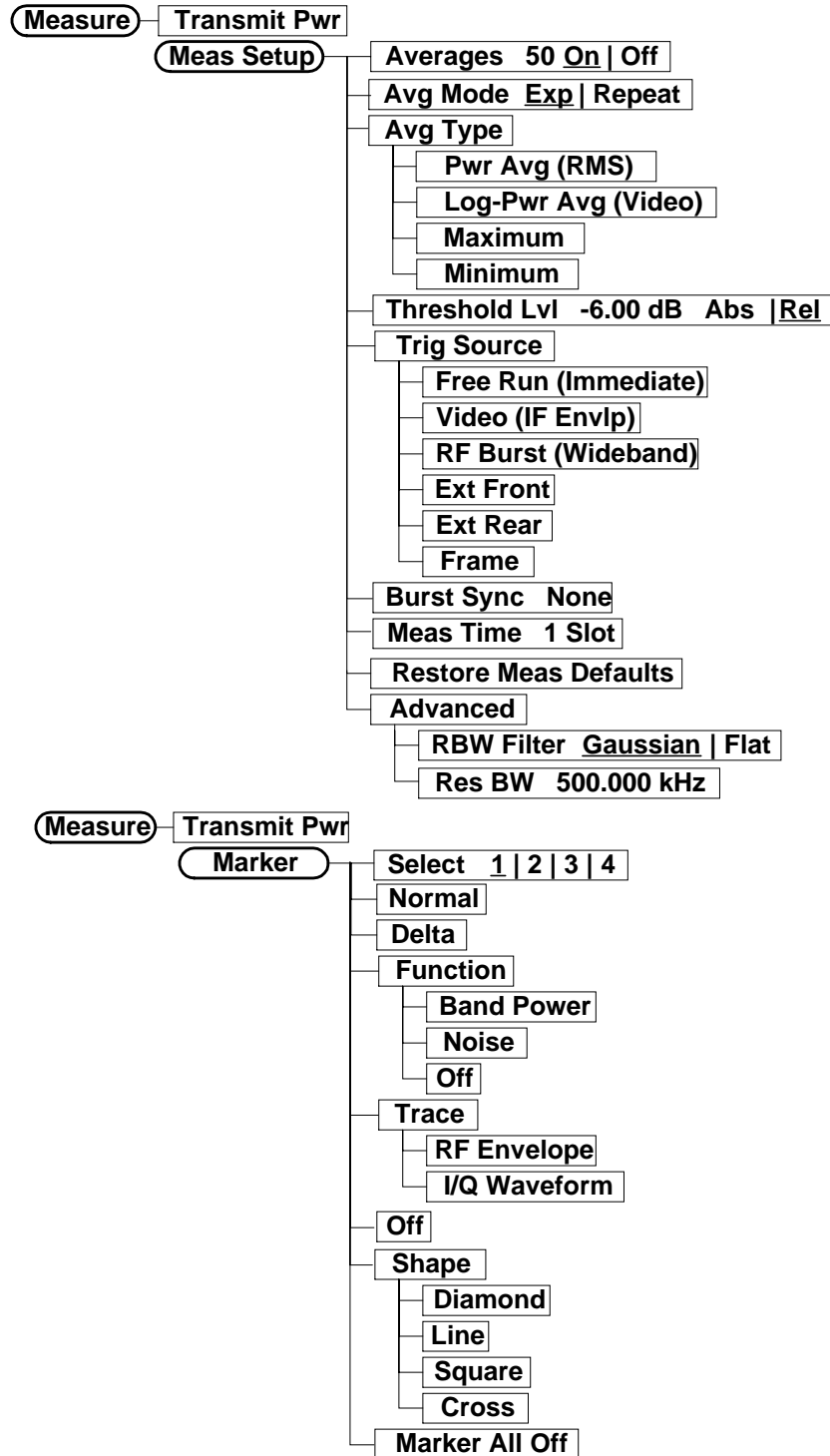
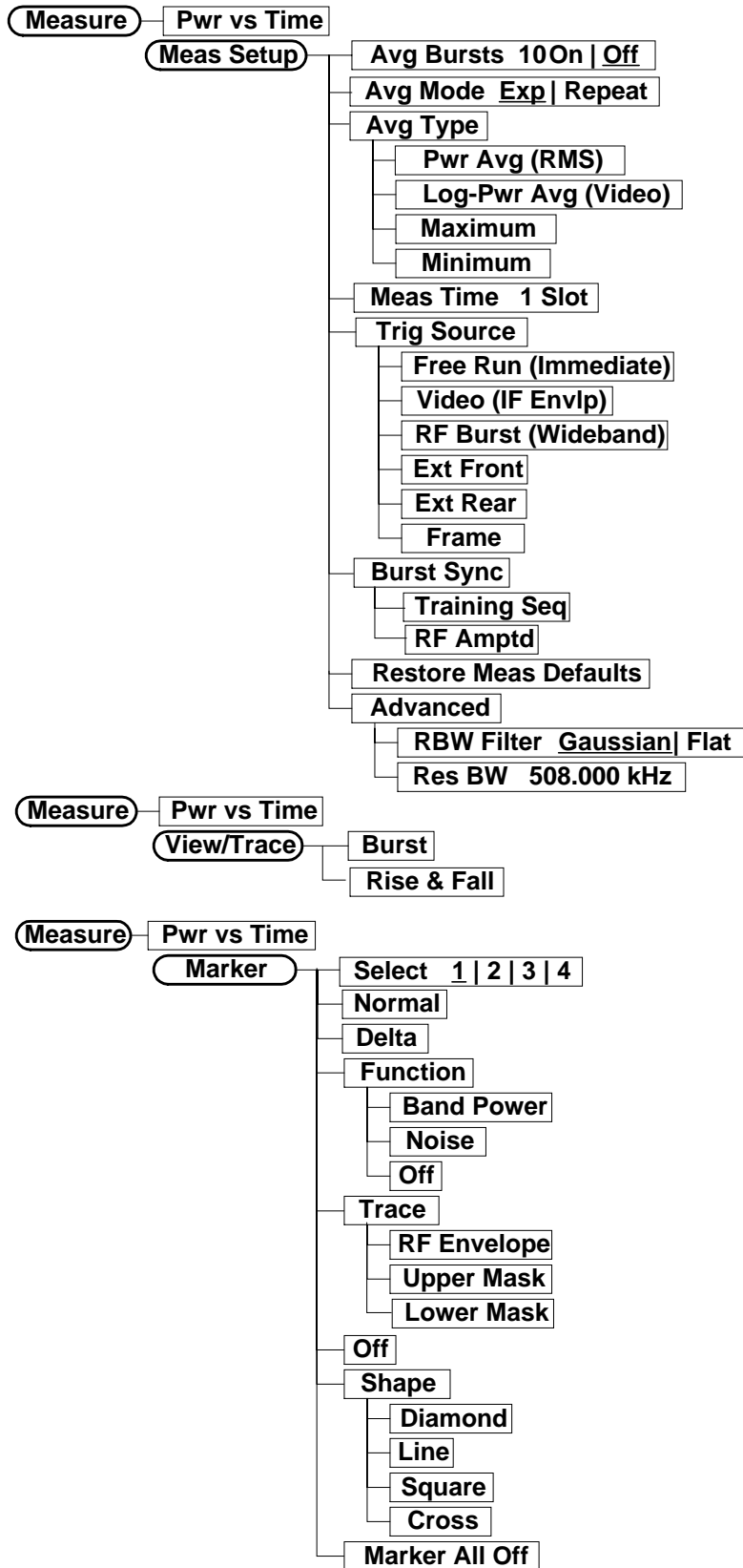

Figure 2-2 Transmit Power Measurement Key Flow



**Figure 2-3 Power vs. Time Measurement Key Flow**



**Figure 2-4 Phase and Frequency Error Measurement Key Flow**

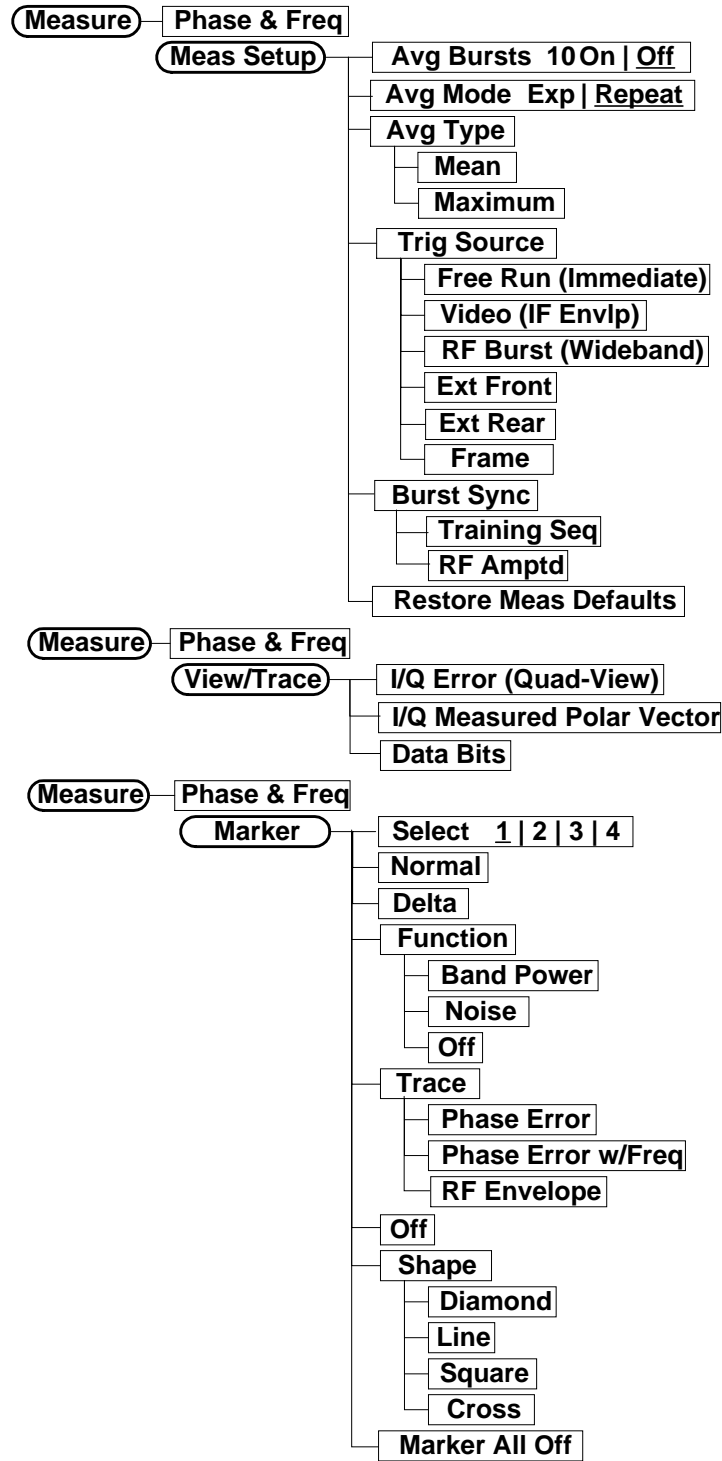

**Figure 2-5 Output RF Spectrum Measurement Key Flow**

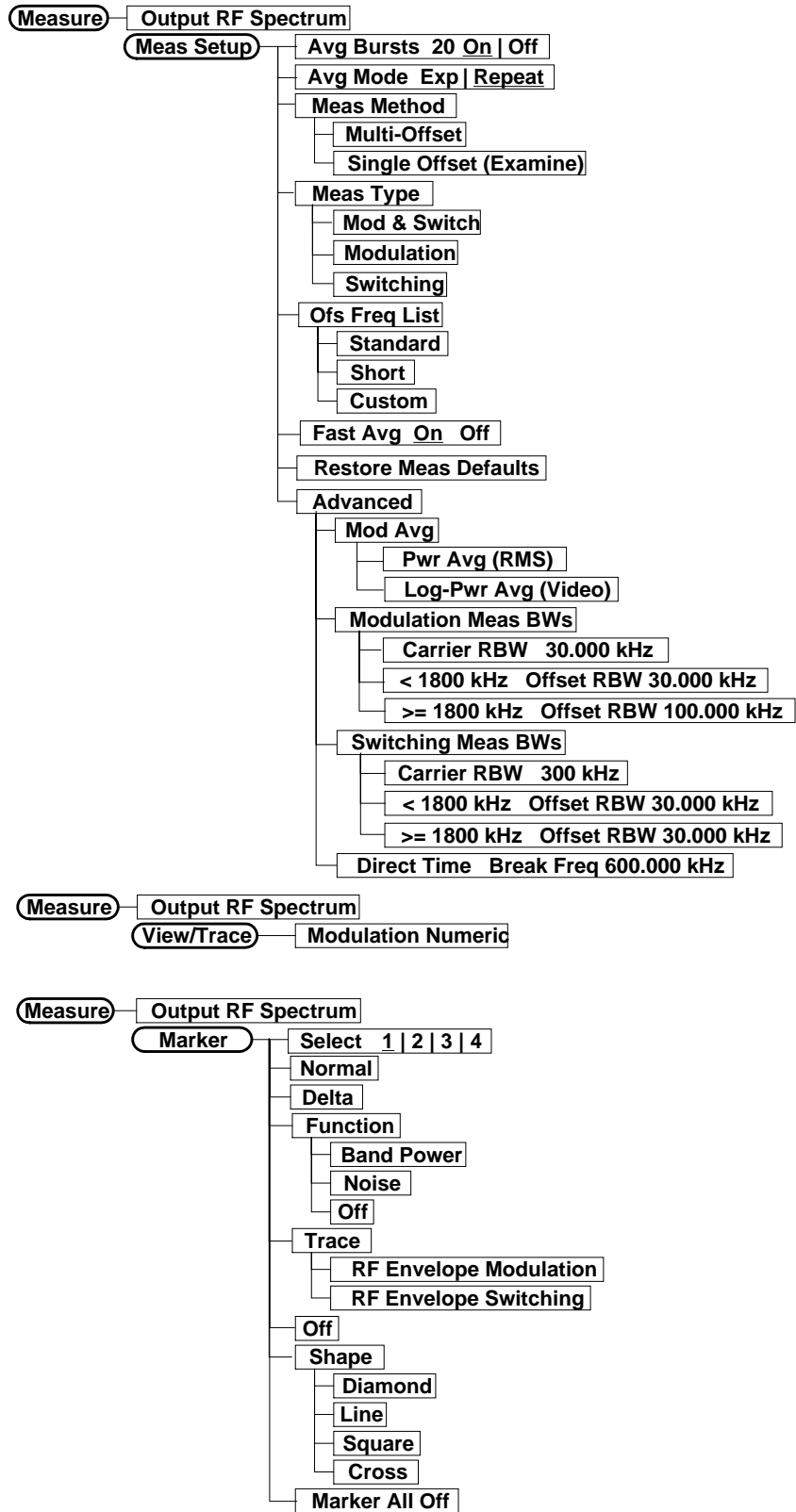
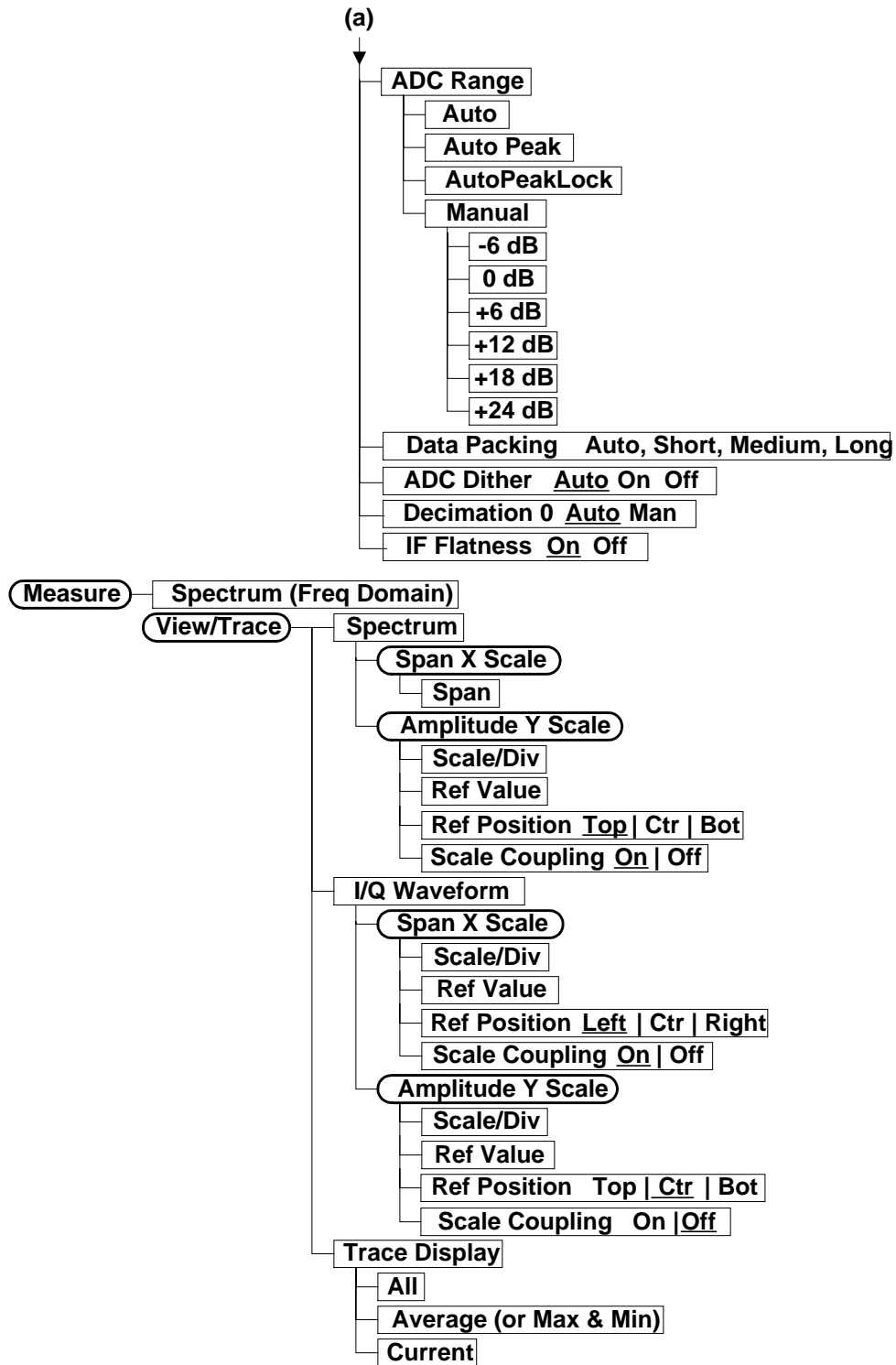



Figure 2-6 Spectrum (Freq Domain) Measurement Key Flow (1 of 3)



**Figure 2-7 Spectrum (Freq Domain) Measurement Key Flow (2 of 3)**



**Figure 2-8 Spectrum (Freq Domain) Measurement Key Flow (3 of 3)**

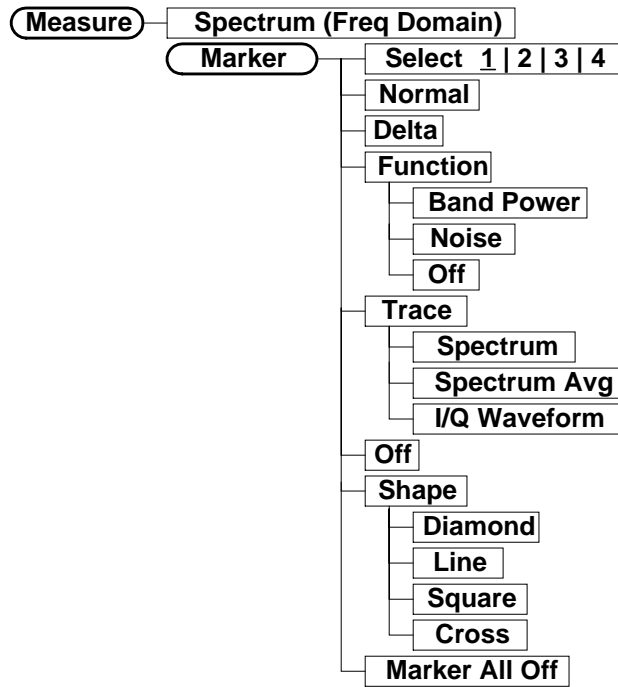

**Figure 2-9 Waveform (Time Domain) Measurement Key Flow (1 of 2)**

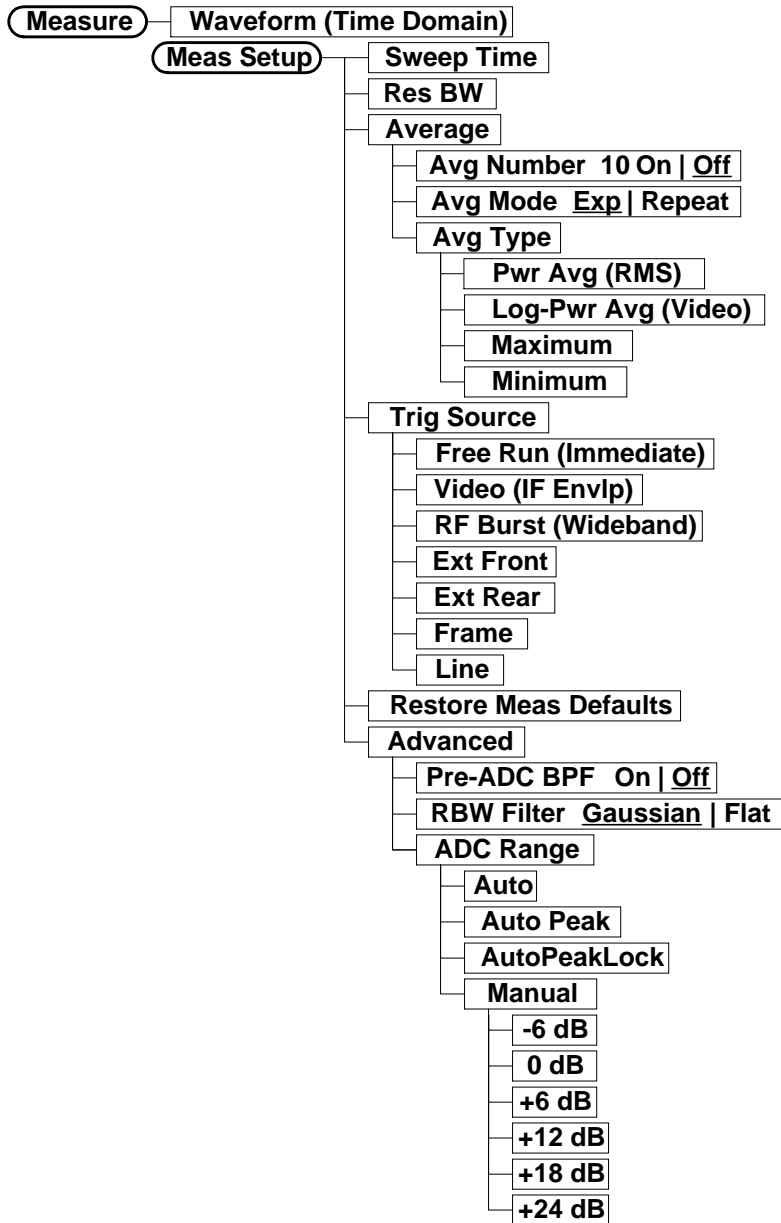

**Figure 2-10 Waveform (Time Domain) Measurement Key Flow (2 of 2)**

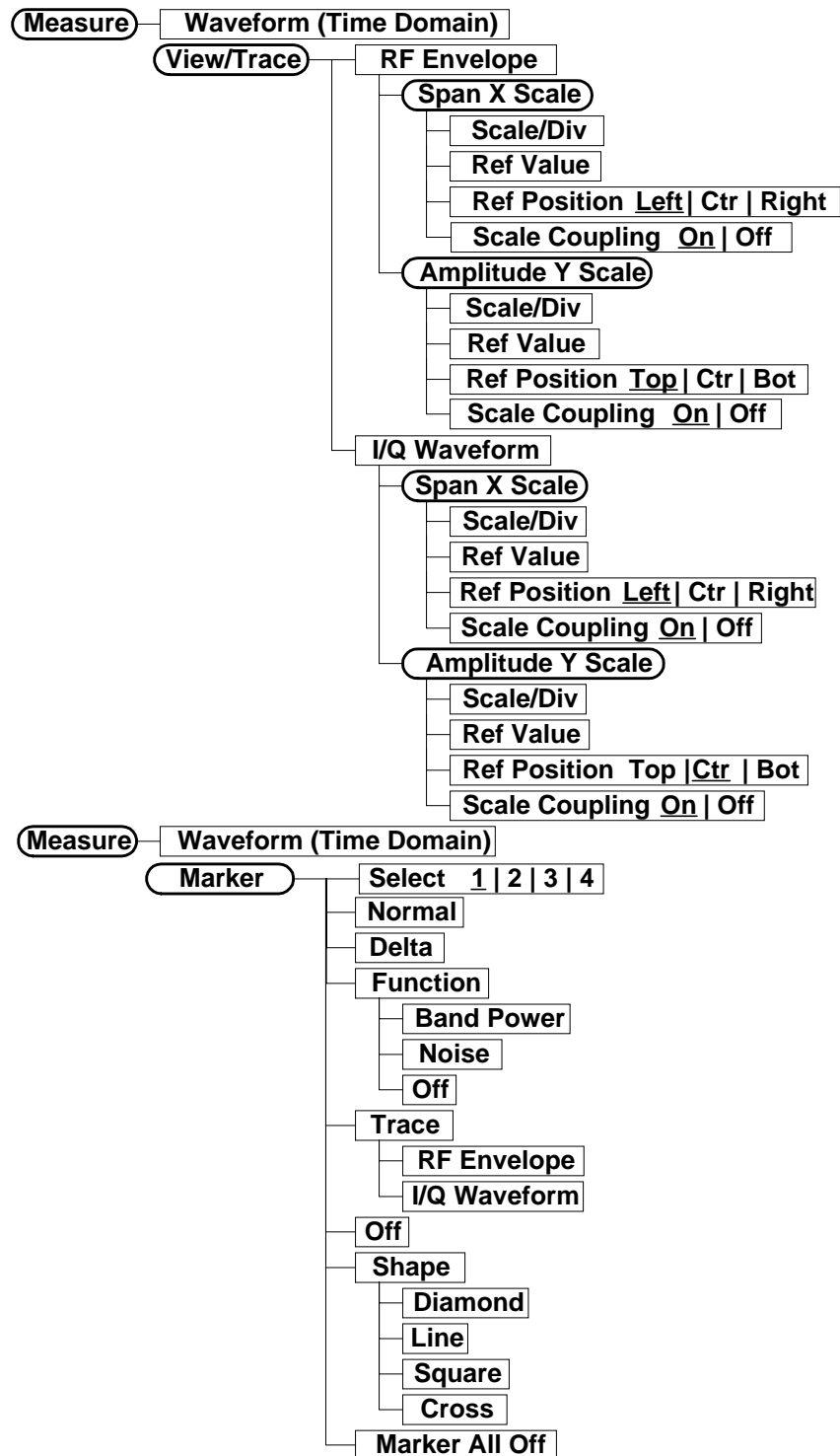

**Figure 2-11 Tx Band Spur Measurement Key Flow**

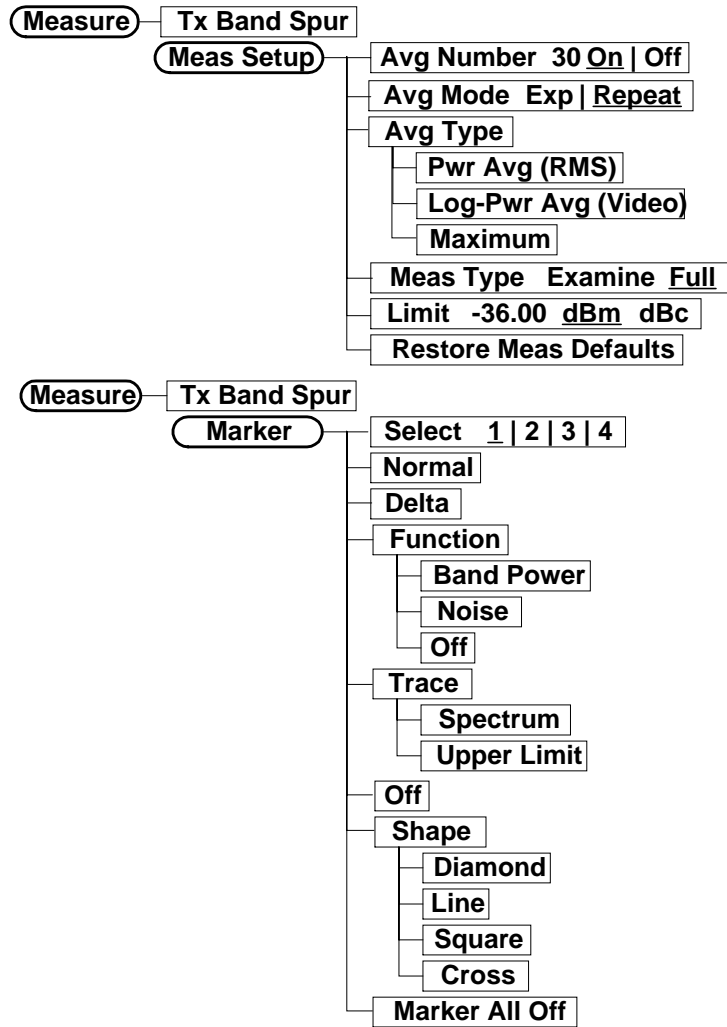
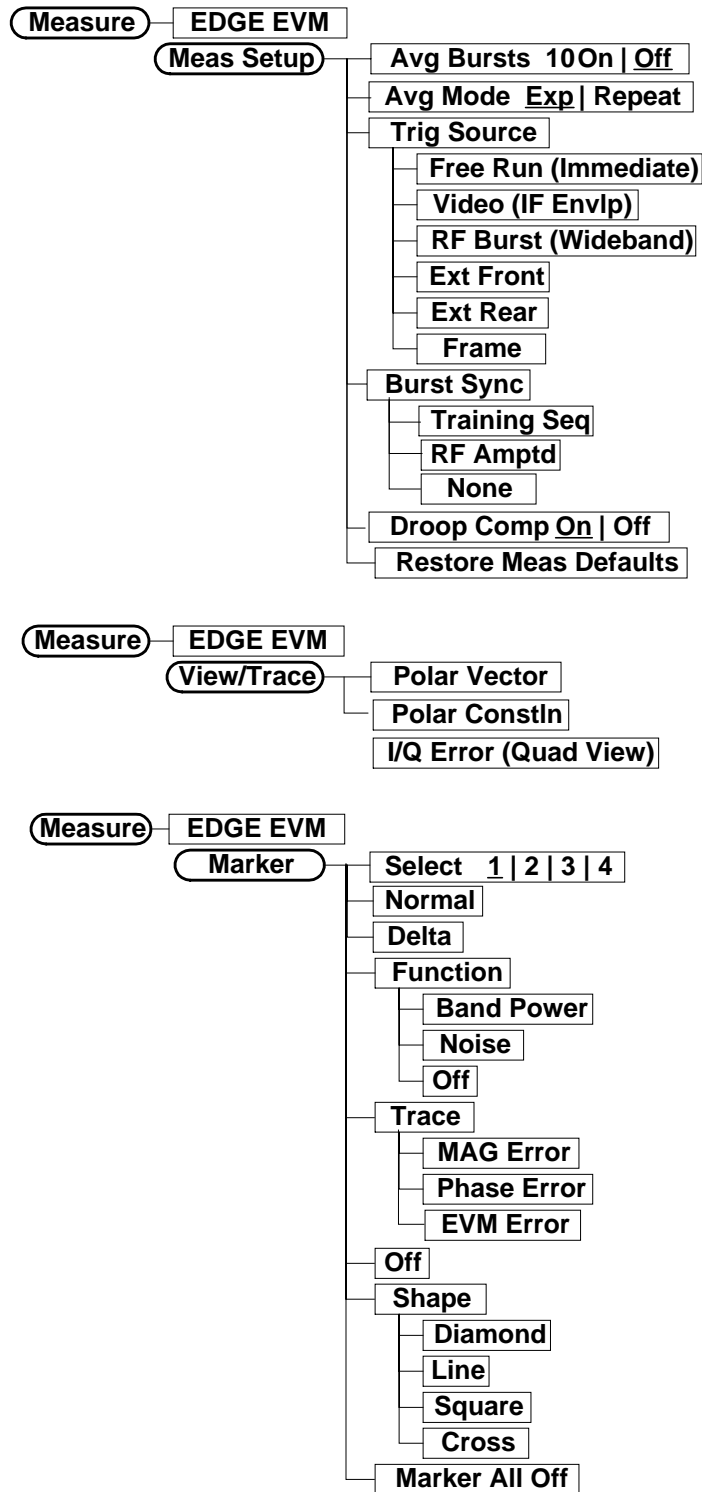
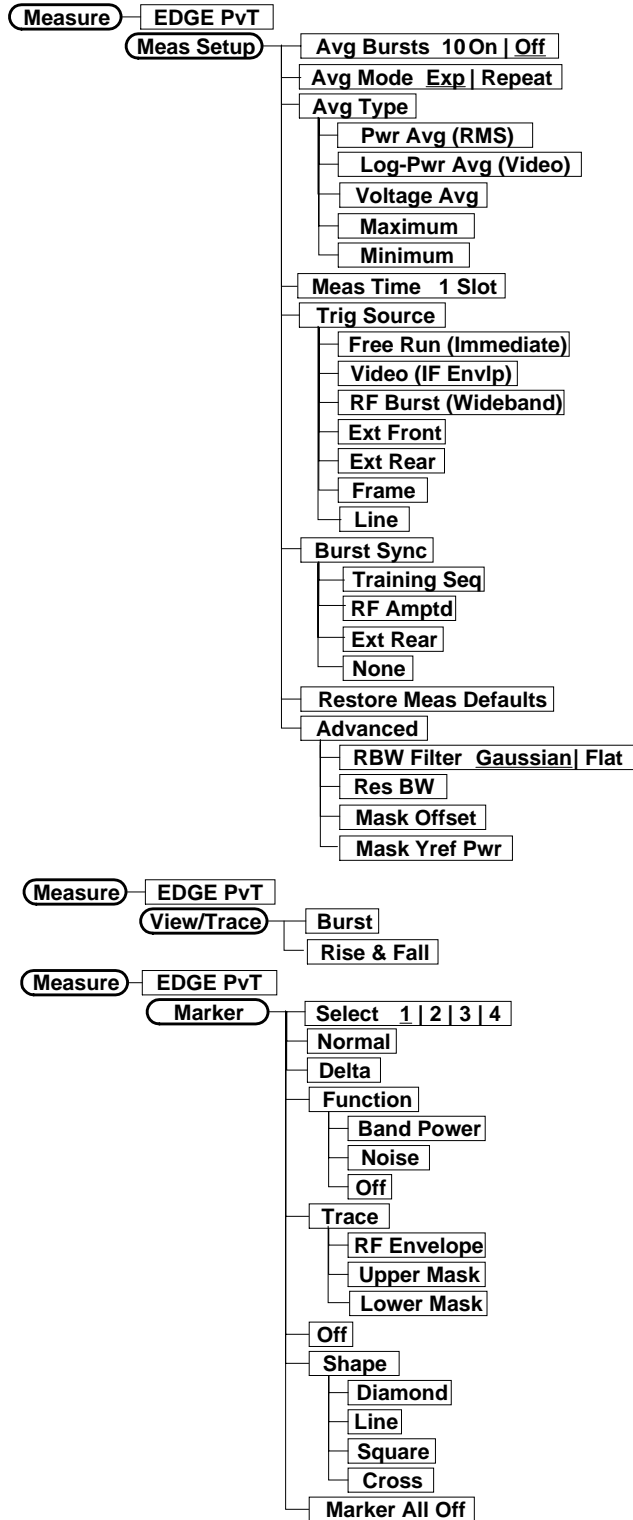

Figure 2-12 EDGE EVM Measurement Key Flow

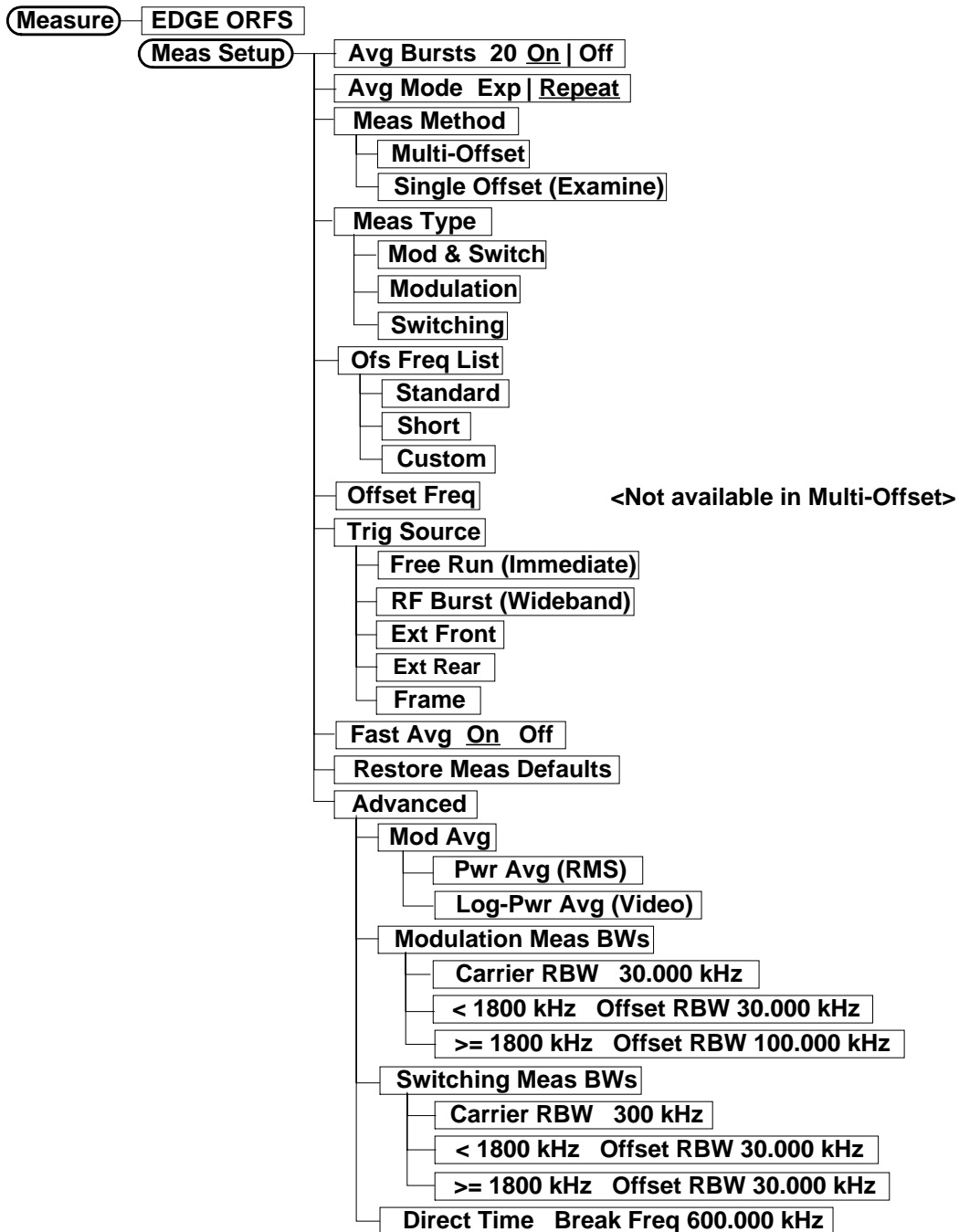

**Figure 2-13**      **EDGE PvT Measurement Key Flow**

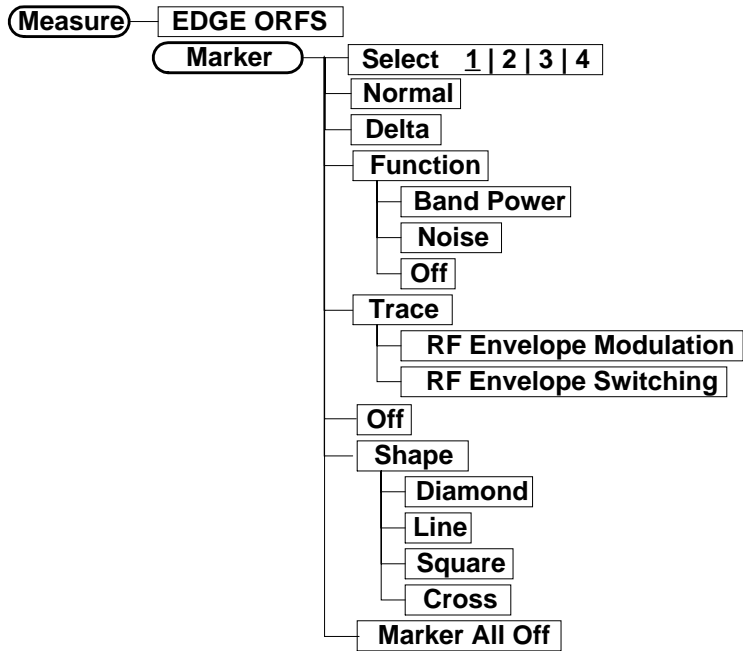



**Figure 2-14 EDGE ORFS Measurement Key Flow (1 of 2)**



**Figure 2-15**      **EDGE ORFS Measurement Key Flow (2 of 2)**



## Installing Optional Measurement Personalities

When you **Install** a measurement personality, you follow a two step process.

1. Install the measurement personality firmware into the instrument. (See the supplied installation instructions.)
2. Enter a license key number to enable the measurement personality. (Refer to the “License Key Numbers” section below.)

Adding additional measurement personalities requires purchasing a retrofit kit for the desired option. The retrofit kit contains the measurement personality firmware. A license key certificate is also included in the kit. It documents the license key number that is for your specific option and instrument serial number. Installation instructions are included with the retrofit kit.

The installation instructions require you to know three pieces of information about your instrument: the amount of memory installed, the Host ID, and the instrument serial number.

Required information:	Key Path:
Instrument Memory: _____	<b>System, File System</b> (the amount of memory in your instrument will be the sum of the <i>Used</i> memory and the <i>Free</i> memory)
Host ID: _____	<b>System, Show System, Host ID</b>
Instrument Serial Number: _____	<b>System, Show System, Serial Number</b>

The **Exit Main Firmware** key is used during the firmware installation process. This key is only for use when you want to update firmware using a LAN connection. The **Exit Main Firmware** key halts the operation of the instrument firmware so you can install an updated version of firmware using a LAN connection. Instructions for loading future firmware updates are available at the following URL:

**[www.agilent.com/find/vsa/](http://www.agilent.com/find/vsa/)**

## Available Personality Options

The option designation consists of three characters, as shown in the **Option** column of the table below.

Available Personality Options <sup>a</sup>	Option
GSM measurement personality	<b>BAH</b>
EDGE (with GSM) measurement personality <sup>b</sup>	<b>202</b>
cdmaOne measurement personality	<b>BAC</b>
NADC, PDC measurement personalities	<b>BAE</b>
iDEN measurement personality	<b>HN1</b>
W-CDMA measurement personality	<b>BAF</b>
cdma2000 measurement personality	<b>B78</b>

a. Available as of the print date of this guide.

b. For instruments that already have Option BAH licensed, order E4406AU Option 252 to add EDGE (with GSM).

## License Key Numbers

Measurement personalities purchased with your instrument have been installed and enabled at the factory. You will receive a unique license key number with every measurement personality purchased. The license key number is a hexadecimal number that is for your specific measurement personality and instrument serial number. It enables you to install, or reactivate that particular personality.

Follow these steps to display the unique license key number for the measurement personality that is installed in your instrument:

1. Press **System, Install, Choose Option**. The **Choose Option** key accesses the alpha editor. Use the alpha editor to enter letters (upper-case) and the front-panel numeric keys to enter digits for a personality option that is already installed in the instrument.
2. Press the **Done** key on the alpha editor menu. The unique license key number for your instrument will now appear on the **License Key** softkey.

*You will want to keep a copy of your license key number in a secure location. Please enter your license key numbers below for future reference. If you should lose your license key number, call your nearest Agilent Technologies service or sales office for assistance.*

<b>License Key Numbers for Instrument with Serial # _____</b>
For Option _____ the license key number is _____
For Option _____ the license key number is _____
For Option _____ the license key number is _____
For Option _____ the license key number is _____
For Option _____ the license key number is _____
For Option _____ the license key number is _____

If you purchase an option later, you will receive a certificate that indicates the unique license key number that you will need to install that option on your particular serial number instrument.

---

**NOTE**

You will need to enter a license key number only if you purchase an additional measurement personality at a later date, or if you want to reactivate a measurement personality that has been deactivated.

---

## **Installing a License Key Number**

---

**NOTE**

Follow this procedure to reinstall a license key number which has been deleted during the uninstall process, or lost due to a memory failure.

---

To install a license key number for the selected option, use the following procedure:

1. Press **System, Install, Choose Option**. The **Choose Option** key accesses the alpha editor menu. Use the alpha editor to enter letters (upper-case) and the front-panel numeric keys to enter numbers for the option designation. Then press the **Done** key. As you enter the option, you will see your entry in the active function area of the display.

Note: that you must already have entered the license key for the GSM option BAH before you can enter the license key for the EDGE retrofit option 252.

2. Press **License Key**. Use the alpha editor to enter letters and the front-panel numeric keys to enter digits. You will see your entry in the active function area of the display. When you have completed entering the license key number, press the **Done** key.

3. Press the **Install Now** key after you have entered the personality option number and the license key number. On some instruments, a message may appear in the function area of the display which reads, "Insert disk and power cycle the instrument". Disregard this message. If you want to proceed with the installation, press the **Yes** key and cycle the instrument power off and then on. Press the **No** key if you wish to cancel the installation process.

## Using the Uninstall Key

The following procedure removes the license key number for the selected option. This will make the option unavailable for use, and the message "Application Not Licensed" will appear in the Status/Info bar at the bottom of the display. Please write down the 12-digit license key number for the option before proceeding. If that measurement personality is to be used at a later date you will need the license key number to reactivate the personality firmware.

---

### NOTE

Using the **Uninstall** key does not remove the personality from the instrument memory, and does not free memory to be available to install another option. If you need to free memory to install another option, refer to the instructions for loading firmware updates located at the URL: [www.agilent.com/find/vsa/](http://www.agilent.com/find/vsa/)

---

1. Press **System, More(1 of 3), More(2 of 3), Uninstall, Choose Option**. Pressing the **Choose Option** key will activate the alpha editor menu. Use the alpha editor to enter the letters (upper-case) and the front-panel numeric keyboard to enter the digits (if required) for the option, then press the **Done** key. As you enter the option, you will see your entry in the active function area of the display.
2. Press the **Uninstall Now** key after you have entered the personality option. Press the **Yes** key if you want to continue the uninstall process. Press the **No** key to cancel the uninstall process.
3. Cycle the instrument power off and then on to complete the uninstall process.

---

## **3 Making EDGE (with GSM) Measurements**

## EDGE (with GSM)Measurements

Once in the EDGE w/GSM mode, the following measurements for the GSM 450, GSM 480, GSM 850, GSM 900, DCS 1800, and PCS 1900 bands are available by pressing the **Measure** key.

- ❑ Transmit Power on [page 54](#)
- ❑ Power vs. Time on [page 59](#)
- ❑ Phase and Frequency Error on [page 64](#)
- ❑ Output RF Spectrum on [page 71](#)
- ❑ Spectrum (Frequency Domain) on [page 83](#)
- ❑ Waveform (Time Domain) on [page 92](#)
- ❑ Tx Band Spur on [page 99](#)
- ❑ EDGE EVM on [page 103](#)
- ❑ EDGE PvT on [page 103](#)
- ❑ EDGE ORFS on [page 103](#)

These are referred to as one-button measurements. When you press the key to select the measurement it will become the active measurement, using settings and a display unique to that measurement. Data acquisitions will automatically begin provided trigger requirements, if any, are met.



## Preparing for Measurements

If you want to set the EDGE w/GSM mode to a known, factory default state, press **Preset**. This will preset the mode setup and all of the measurements to the factory default parameters.

**NOTE**

Pressing the **Preset** key does not switch instrument modes.

To preset only the settings that are specific to the selected measurement, press **Meas Setup, More, Restore Meas Defaults**. This will set the measure setup parameters, for the currently selected measurement only, to the factory defaults.

### Initial Setup

Before making a measurement, make sure the mode setup and frequency/channel parameters are set to the desired settings. Refer to the sections “[Changing the Mode Setup](#)” and “[Changing the Frequency Channel](#)” in the previous chapter.

### How to Make a Measurement

Follow the three-step process shown in the table below:

Step	Primary Key	Setup Keys	Related Keys
1. Select & setup a mode	Mode	Mode Setup, Input, Frequency Channel	System
2. Select & setup a measurement	Measure	Meas Setup	Meas Control, Restart
3. Select & setup view	View/Trace	Span X Scale, Amplitude Y Scale, Display, Next Window, Zoom	File, Save, Print, Print Setup, Marker, Search

## Measurement Control

The **Meas Control** front panel menu key controls processes that affect the running of the current measurement.

- **Measure** softkey. Press **Meas Control**, **Measure** (not to be confused with the front panel **Measure** key which has a different function) to toggle between **Single** and **Cont** (for continuous) measurement states. When set to **Single**, the measurement will continue until it has reached the specified number of averages set by the average counter. When set to **Continuous**, the measurement will run continuously, and perform averaging according to the current average type (repeat or exponential). The default setting is continuous.
- **Pause** key. Press **Meas Control**, **Pause** to pause the current measurement. Once toggled, the label of the **Pause** key changes to read **Resume**. The **Resume** key, once pressed, continues the active measurement from the point at which it was paused.
- **Restart** key. The **Restart** front panel key repeats the current measurement from the beginning, while retaining the current measurement settings.

## Measurement Setup

The **Meas Setup** key accesses features that enable you to adjust parameters of the current measurement, such as resolution bandwidth. You will also use the **Meas Setup** menu to access the **Average**, **Trig Source**, and **Advanced** measure setup feature menus.

The following measure setup features can be used with many or all measurements.

- **Res BW** key. Press **Meas Setup**, **Res BW** to change the resolution of a given measurement. Selection of a narrower bandwidth will result in a longer data acquisition time.
- **Restore Meas Defaults** key. To preset only the settings that are specific to the selected measurement, press **Meas Setup**, **More**, **Restore Meas Defaults**. This will set the measure setup parameters, for the currently selected measurement only, to the factory defaults.

### EDGE (with GSM) Averaging

Selecting one of the averaging keys in the **Meas Setup** menu will allow you to modify the number, averaging mode, and type of averaging you use for the currently selected measurement.

- **Averages**, **Avg Bursts On Off**, or **Avg Number** - Allows you to select whether averages are made or not.
- **Avg Mode Exp Repeat** - Allows you to choose either exponential or repeat averaging. This selection only effects the averaging after the number of N averages is reached (set using the **Averages**, **Avg Bursts**, or **Avg Number** key).
  - **Exponential averaging**: When **Measure** is set at **Cont**, data acquisitions will continue indefinitely. After N averages, exponential averaging is used with a weighting factor of N (the displayed average count stops at N). Exponential averaging weights new data more than old data, which allows tracking of slow-changing signals. The weighting factor N is set using the **Averages**, **Avg Bursts**, or **Avg Number** key.
  - **Repeat averaging**: When **Measure** is set at **Cont**, data acquisitions will continue indefinitely. After N averages is reached, all previous result data is cleared and the average count is set back to 1. This is equivalent to being in **Measure Single** and pressing the **Restart** key each time the Single measurement finishes.

- **Avg Type** - Select the averaging type from the following selections:  
(Not all of the selections are available for all measurements)
  - Pwr Avg (RMS)** - The true power averaging, and is equivalent to taking the RMS of the voltage. It is the most accurate type.
  - Log-Pwr Avg (Video)** - Simulates the traditional spectrum analyzer type of averaging by averaging the log of the power.
  - Mean** - Averages the mean values.
  - Voltage Avg** - Averages the voltage values.
  - Maximum** - Keeps track of the maximum values.
  - Minimum** - Keeps track of the minimum values.
  - Max & Min** - Keeps track of the maximum and minimum values.

### Trig Source

Changing the selection in the **Trig Source** menu alters the trigger source for the selected measurement only. Not all of the selections are available for all measurements. Note that the **RF Burst (Wideband)**, **Video (IF Envlp)**, **Ext Front**, and **Ext Rear** menu keys found in the **Trigger** menu enable you to change settings to modify the delay, level, and slope for each of these trigger sources. Choose one of the following trigger sources:

- **Free Run (Immediate)** - The trigger occurs at the time the data is requested, completely asynchronous to the RF or IF signal.
- **RF Burst (Wideband)** - An internal wideband RF burst trigger that has an automatic level control for burst signals. It triggers on a level that is relative to the peak of the signal passed by the RF.
- **Video (IF Envlp)** - An internal IF envelope trigger. It triggers on an absolute threshold level of the signal passed by the IF.
- **Ext Front** - Activates the front panel external trigger input (**EXT TRIGGER INPUT**). The external trigger must be a signal between  $-5$  and  $+5$  volts.
- **Ext Rear** - Activates the rear panel external trigger input (**TRIGGER IN**). The external trigger must be a signal between  $-5$  and  $+5$  volts.
- **Frame** - Uses the internal frame clock to generate a trigger signal. The clock parameters are controlled under the **Mode Setup** key or the measurement firmware, not both. See the specific measurement for details.

Rear panel **TRIGGER 1 OUT** and **TRIGGER 2 OUT** connectors are coupled to the selected trigger source. These trigger outputs are always on the rising edge with a pulse width of at least  $1 \mu\text{s}$ .

## Burst Sync

Pressing the **Burst Sync** key allows you to choose the source used to synchronize the measurement to the “T0” point of the GSM burst. The “T0” point is defined as the time point of the transition from bit 13 to bit 14 of the midamble training sequence for a given time slot. The **Burst Search Threshold** setting (in the **Mode Setup** keys under **Trigger**) applies to both **Training Seq** and **RF Amptd**. It is described on [page 22](#). Pressing the **Burst Sync** key will bring up a menu with some or all of the following choices:

- **Training Seq** - Synchronizes the measurement to the timing of the demodulated training sequence in the GSM burst. This is the most precise method, but requires a GSM burst with a valid TSC (Training Sequence Code). The “T0” point is determined by demodulation of the burst and successful identification of the TSC. “T0” is then found to within 1/10 bit.
- **RF Amptd** - Synchronizes the measurement to the burst transition of the measured RF carrier. “T0” is set to the 50% point between the start and end of the burst.
- **None** - Use the start of the time record as the start of the useful part. “T0” is set to the middle of the useful part.
- **Ext** - Use the external trigger plus delay as the start of the useful part. “T0” is set to the middle of the useful part.

## Making the Transmit Power Measurement

### Purpose

Transmit Power is the measure of in-channel power for EDGE (with GSM) systems. Mobile stations and base transceiver stations must transmit enough power, with sufficient modulation accuracy, to maintain a call of acceptable quality without leaking into frequency channels or timeslots allocated for others. EDGE (with GSM) systems use dynamic power control to ensure that each link is maintained with minimum power. This gives two fundamental benefits: overall system interference is kept to a minimum and, in the case of mobile stations, battery life is maximized.

The Transmit Power measurement determines the average power for an RF signal burst at or above a specified threshold value. The threshold value may be absolute, or relative to the peak value of the signal.

At the base transceiver station, the purpose of the Transmit Power measurement is to determine the power delivered to the antenna system on the radio-frequency channel under test. The Transmit Power measurement verifies the accuracy of the mean transmitted RF carrier power. This can be done across the frequency range and at each power step.

### Measurement Method

The instrument acquires a EDGE (with GSM) signal in the time domain. The average power level above the threshold is then computed and displayed. This measurement uses the “power-above-threshold” method instead of the “useful part of the burst” method defined in the EDGE (with GSM) standards. The measured Transmit Carrier Power will be very nearly the same for these two methods. The power-above-threshold method has the advantages of being faster and allows power measurements to be made at somewhat lower power levels. It also has the advantage of not requiring the carrier to have a valid TSC (Training Sequence Code).

Note that this measurement does not provide a way to specify which timeslot is to be measured. Therefore if multiple timeslots are on, they should all be set at the same power level, or the levels of those timeslots to be excluded need to be kept below the threshold level. If you want to measure Transmit Carrier Power using the GSM specified useful part of the burst method, use the Power vs. Time measurement, which also measures the power ramping of the burst.

## Making the Measurement

---

NOTE

The factory default settings provide a EDGE (with GSM) compliant measurement. For special requirements, you may need to change some of the settings. Press **Meas Setup, More (1 of 2), Restore Meas Defaults** at any time to return all parameters for the current measurement to their default settings.

---

Select the desired ARFCN, center frequency, timeslot, burst type, and TSC (Training Sequence Code) as described in the section titled [“Changing the Frequency Channel” on page 24](#).

Press **Measure, Transmit Pwr** to immediately make Transmit Power the active measurement.

To change any of the measurement parameters from the factory default values, refer to the [“Changing the Measurement Setup”](#) section for this measurement.

## Results

**Figure 3-1** Transmit Power Result - Single Burst

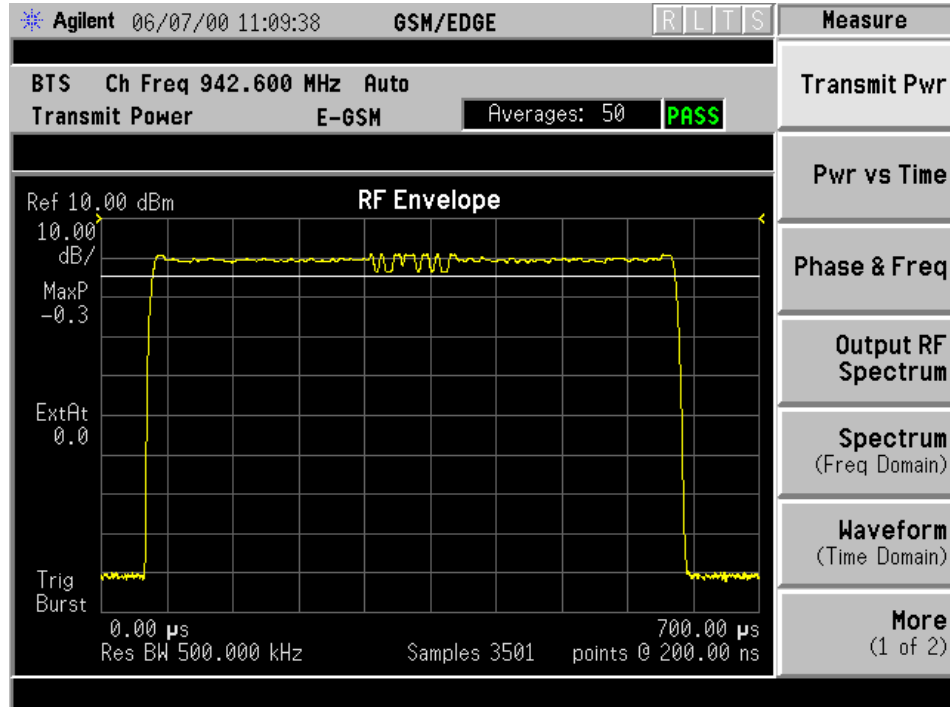

**Figure 3-2** Transmit Power Result - Multiple Bursts

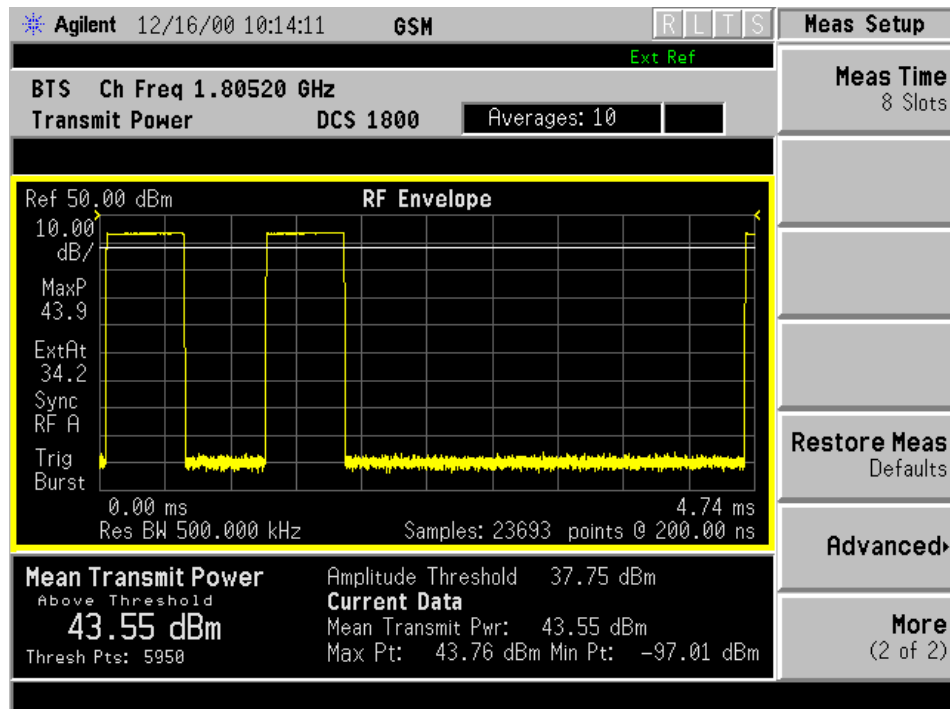



## Changing the Measurement Setup

**Table 3-1** Transmit Power Measurement Defaults

Measurement Parameter	Factory Default Condition
Averages	50 On
Avg Mode	Exp
Avg Type	Pwr Avg (RMS)
Threshold Lvl	-6.00 dB Rel (to peak)
Trig Source	RF Burst (Wideband)
Burst Sync	None
Meas Time	1 slot
<b>Advanced</b>	
RBW Filter	Gaussian
Res BW	500.000 kHz

**NOTE**

Parameters that are under the **Advanced** key seldom need to be changed. Any changes from the factory default values may result in invalid measurement data.

Make sure the Transmit Power measurement is selected under the **Measure** menu. Press the **Meas Setup** key to access a menu which allows you to modify the averaging, trigger source, and burst sync for this measurement (as described in the “[Measurement Setup](#)” section at the beginning of this chapter). In addition, the following transmit power measurement parameters can be modified:

- **Threshold Lvl Abs Rel** - choose absolute or relative and enter a value for the threshold level. The absolute value sets the threshold line at that power level. The relative value will set the threshold line at a specified level relative to the peak of the burst. The measurement will determine the average power of all data above this threshold.
- **Burst Sync** - an information only key. The selection cannot be changed for this measurement.
- **Meas Time** - allows you to measure more than one timeslot. Enter an integer value in increments of “slots” with a range of 1 to 50. The actual measure time is set somewhat longer than the specified number of slots in order to view the complete burst.

- **Advanced** - accesses a menu to change the following parameters:

**RBW Filter** - this key toggles to select a Flat Top or a Gaussian (the default filter) resolution bandwidth filter. A Gaussian filter provides more even time domain response, particularly for bursts. A Flat Top filter provides a flatter bandwidth but is less accurate for pulse responses. A Flat Top filter also requires less memory and allows longer data acquisition times.

**Res BW** - sets the resolution bandwidth.

## Troubleshooting Hints

Low output power can lead to poor coverage and intermittent service for phone users. Out of specification power measurements indicate a fault usually in the power amplifier circuitry. They can also provide early indication of a fault with the power supply, i.e. the battery in the case of mobile stations.

## Making the Power vs. Time Measurement

### Purpose

Power vs. Time measures the mean transmit power during the “useful part” of GSM bursts and verifies that the power ramp fits the within the defined mask. Power vs. Time also lets you view the rise, fall, and “useful part” of the GSM burst.

GSM is a Time Division Multiple Access (TDMA) scheme with eight time slots, or bursts, per RF channel. If the burst does not occur at exactly the right time, or if the burst is irregular, then other adjacent timeslots can experience interference. Because of this, the industry standards specify a tight mask for the fit of the TDMA burst.

The Power vs. Time measurement provides masks for both BTS (Base Transceiver Station) and MS (mobile station). The timings are referenced to the transition from bit 13 to bit 14 of the midamble training sequence. The 0 dB reference is determined by measuring the mean transmitted power during the “useful part” of the burst. You can also define a user configurable limit mask to apply to the measured burst using SCPI commands (refer to the [“Changing the Measurement Setup”](#) section).

The GSM specifications defines the “useful part” of the normal GSM burst as being the 147 bits centered on the transition from bit 13 to bit 14 (the “T0” time point).

### Measurement Method

The instrument acquires a EDGE or GSM signal in the time domain. The “T0” point and the useful part are computed. If Burst Sync is set to **Training Seq**, a GSM demodulation is performed to find “T0”. If Burst Sync is set to **RF Amptd**, an approximation of “T0” will be used without performing a demodulation. The average power in the useful part is then computed and displayed, and the GSM limit mask is applied. The measurement displays `PASS` when the burst fits within the bounds of the mask.

## Making the Measurement

---

NOTE

The factory default settings provide a EDGE (with GSM) compliant measurement. For special requirements, you may need to change some of the settings. Press **Meas Setup, More (1 of 2), Restore Meas Defaults** at any time to return all parameters for the current measurement to their default settings.

---

Select the desired ARFCN, center frequency, timeslot, burst type, and TSC (Training Sequence Code) as described in the section titled [“Changing the Frequency Channel” on page 24](#).

**Timeslot** is available when **Burst Sync** is either **Training Sequence** or **RF Amptd**.

The timeslots are determined by taking the acquired data and dividing it into timeslots 0 to 7. An active timeslot burst must be within approximately 25% of the expected timeslot position, otherwise the E4406A may think the burst is an adjacent timeslot and may not detect it. The trigger delay can be used to position the signal if it is not aligning in the timeslots as desired.

Press **Measure, Pwr vs Time** to immediately make Power vs. Time the active measurement.

To change any of the measurement parameters from the factory default values, refer to the [“Changing the Measurement Setup”](#) section for this measurement.

## Results

Figure 3-3

### Power vs. Time Measurement Result - Burst View

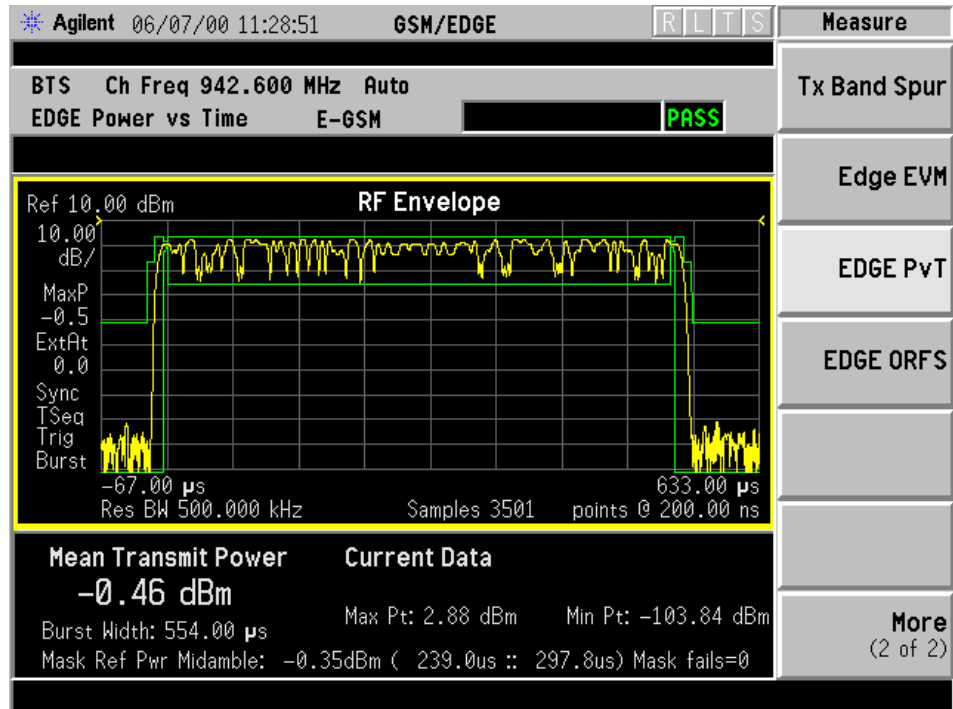

## Changing the Measurement Setup

**Table 3-2** Power vs. Time Measurement Defaults

Measurement Parameter	Factory Default Condition
Avg Bursts	10 Off
Avg Mode	Exp
Avg Type	Pwr Avg (RMS)
Meas Time	1 Slot
Trig Source	RF Burst (Wideband)
Burst Sync	Training Seq
<b>Advanced</b>	
RBW Filter	Gaussian
Res BW	500.000 kHz

---

**NOTE**

Parameters that are under the **Advanced** key seldom need to be changed. Any changes from the default values may result in invalid measurement data.

Make sure the Power vs. Time measurement is selected under the **Measure** menu. The **Meas Setup** key will access a menu which allows you to modify the averaging, trigger source, and burst sync for this measurement (as described in the “[Measurement Setup](#)” section at the beginning of this chapter). In addition, the following power vs. time measurement parameters can be modified:

- **Meas Time** - allows you to measure more than one timeslot. Enter a value in integer increments of “slots” with a range of 1 to 50. The actual measure time in  $\mu\text{s}$  is set somewhat longer than the specified number of slots in order to view the complete burst.
- **Advanced** - accesses a menu to change the following parameters:

**RBW Filter** - chooses the type of filter, either **Gaussian** or **Flat** (Flatop). Gaussian is the best choice when looking at the overall burst or the rising and falling edges, as it has excellent pulse response. If you want to precisely examine just the useful part of the burst, choose **Flat**.

**Res BW** - sets the resolution bandwidth.

### Power vs. Time Custom Masks

For the Power vs. Time measurement, you can define a user configurable limit mask to apply to the measured burst. This feature can only be accessed via SCPI commands. Refer to the programming manual for further information.

## Changing the View

The **View/Trace** key will access a menu which allows you to select the desired view of the measurement from the following selections:

- **Burst** - views the entire sweep as specified by the meas time.
- **Rise & Fall** - zooms in on the rising and falling portions of the burst being tested.

---

NOTE

---

The limit test will still be performed on the entire burst, (viewed using the **Burst** menu), when **Rise & Fall** is selected.

## Changing the Display

The **Display** key will allow you to turn the limit mask on and off. This also disables the mask limit test, but still calculates the power in the useful part.

## Troubleshooting Hints

If a transmitter fails the Power vs. Time measurement this usually indicates a problem with the units output amplifier or leveling loop.

## **Making the Phase and Frequency Error Measurement**

### **Purpose**

Phase and frequency error are the measures of modulation quality for GSM systems. Since GSM systems use relative phase to transmit information, the phase and frequency accuracy of the GSM transmitter are critical to the systems performance and ultimately affect range.

GSM receivers rely on the phase and frequency quality of the 0.3 GMSK signal in order to achieve the expected carrier to noise performance. A transmitter with high phase and frequency error will often still be able to support phone calls during a functional test. However, it will tend to provide difficulty for mobiles trying to maintain service at the edges of the cell, with low signal levels or under difficult fading and Doppler conditions.

### **Measurement Method**

The phase error of the test signal is measured by computing the difference between the phase of the transmitted signal and the phase of a theoretically perfect signal.

The instrument samples the transmitter output in order to capture the actual phase trajectory. This is then demodulated and the ideal phase trajectory is mathematically derived. Subtracting one from the other results in an error signal.

This measurement allows you to display these errors numerically and graphically on the analyzer display. It also allows you to view a binary representation of the demodulated data bits.



## Making the Measurement

---

NOTE

The factory default settings provide a GSM compliant measurement. For special requirements, you may need to change some of the settings. Press **Meas Setup, More (1 of 2), Restore Meas Defaults** at any time to return all parameters for the current measurement to their default settings.

---

Select the desired ARFCN, center frequency, timeslot, burst type, and TSC (Training Sequence Code) as described in the section titled [“Changing the Frequency Channel” on page 24](#).

Select the type of carrier to measure. Press **Mode Setup, Radio, Carrier** and select **Burst** to measure a burst carrier, or **Cont** to measure a continuous carrier from a non-bursting base station.

When **Training Sequence** is selected as the burst sync for this measurement, set the **Timeslot** selection to determine which timeslot to measure. For example, if **Timeslot** is set to 2, the measurement will be made on the timeslot number 2. Be careful when adding delay in the **Trigger** setup, as this measurement does not take into account trigger delay when checking for a valid burst. If there is sufficient delay added (usually more than 25% of a timeslot), the burst might not be detected.

Press **Measure, Phase & Freq** to immediately make Phase and Frequency Error the active measurement.

To change any of the measurement parameters from the factory default values, refer to the [“Changing the Measurement Setup”](#) section for this measurement.

## Results

**Figure 3-4** Phase and Frequency Error Result - Quad View

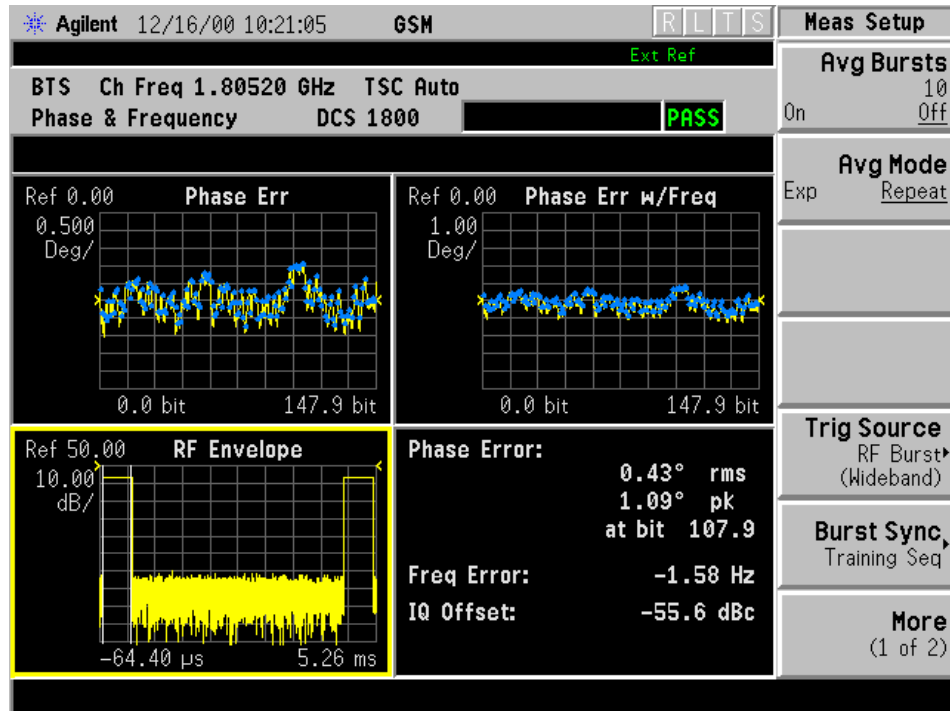

**Figure 3-5 Phase and Frequency Error Result - Phase Error View**

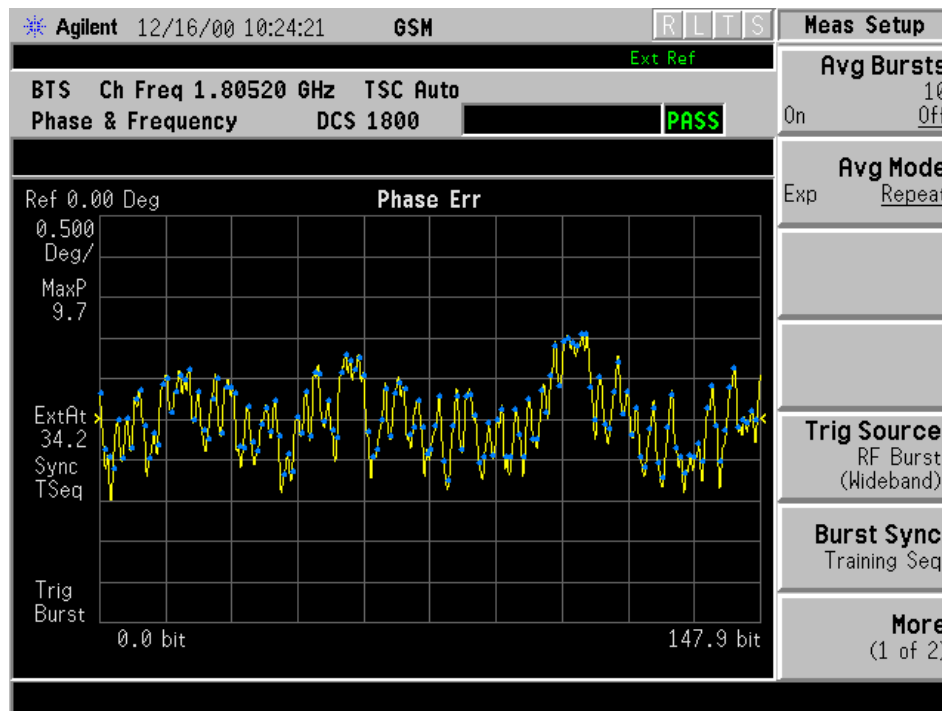

**Figure 3-6 Phase and Frequency Error Result - RF Envelope View**

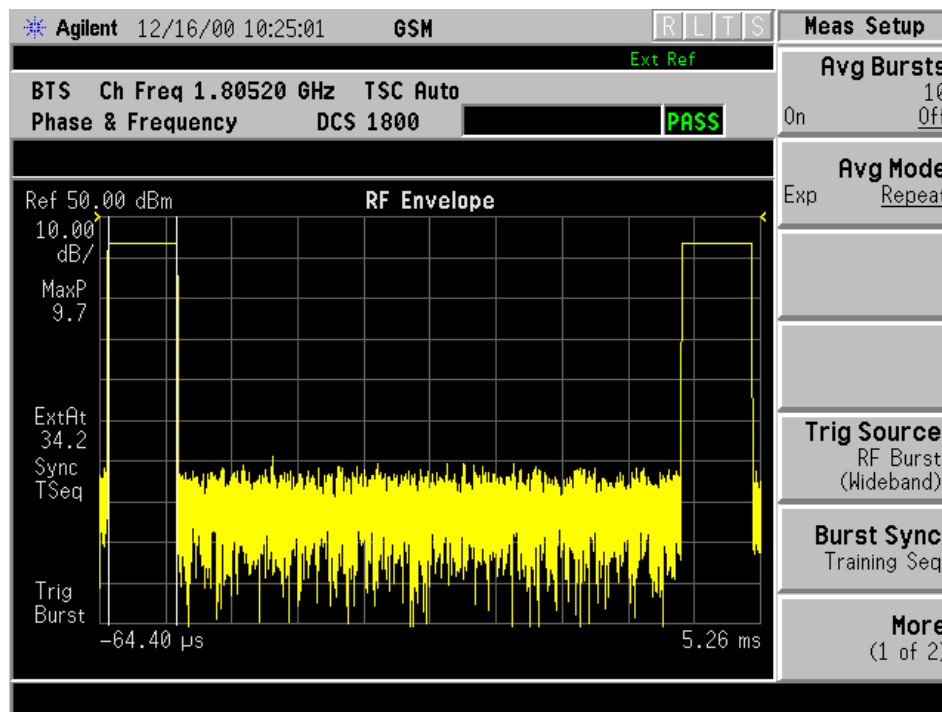

**Figure 3-7 Phase and Frequency Error Result - Polar View**

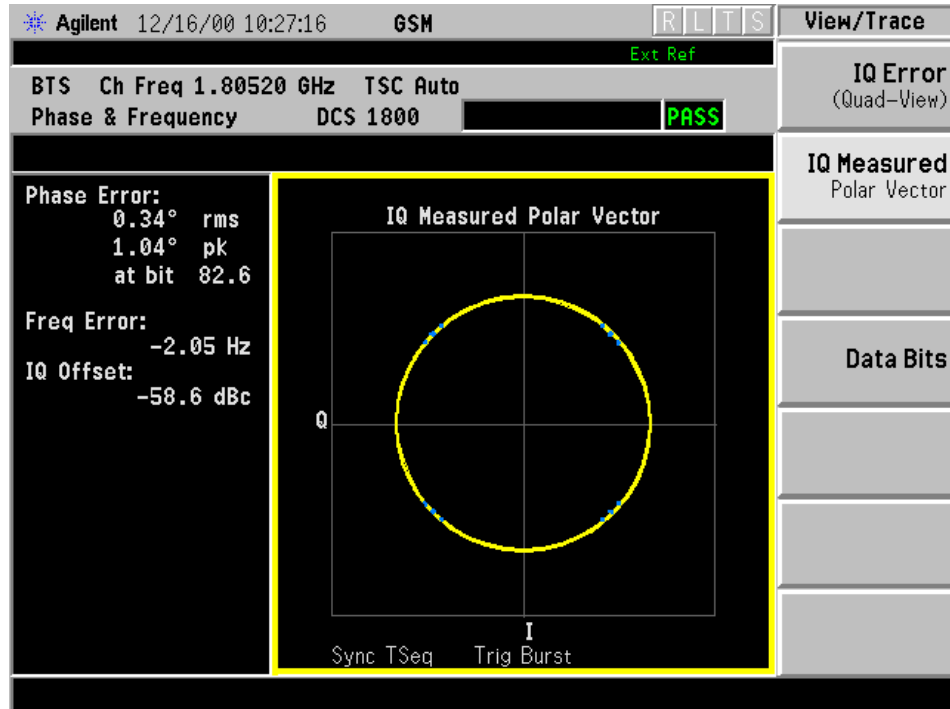

**Figure 3-8 Phase and Frequency Error Result - Data Bits**

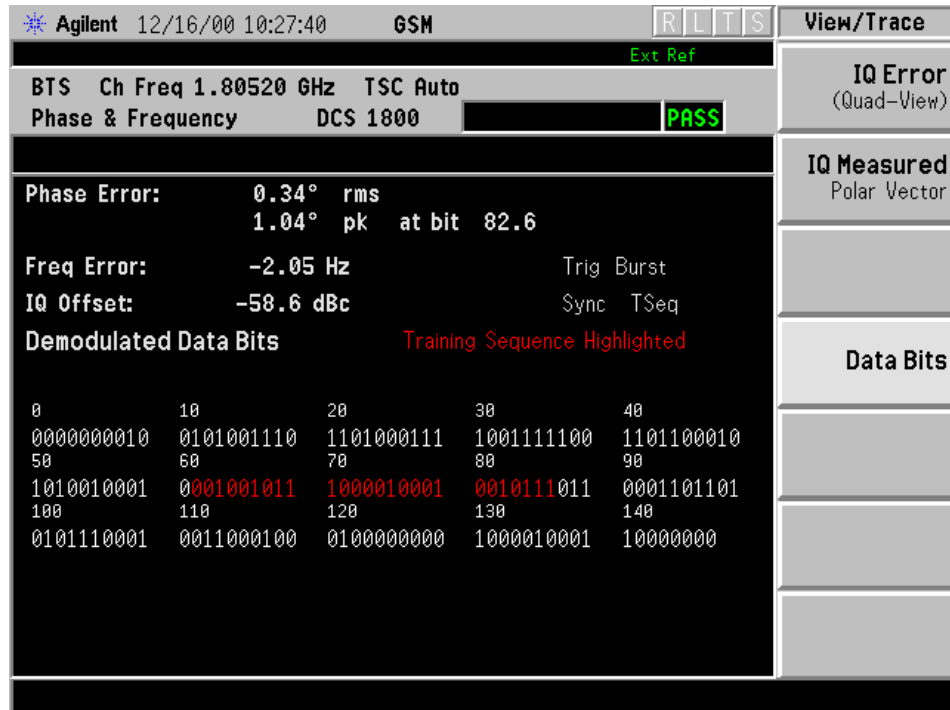

## Changing the Measurement Setup

**Table 3-3** Phase and Frequency Error Measurement Defaults

Measurement Parameter	Factory Default Condition
Avg Bursts	10 Off
Avg Mode	Repeat
Avg Type	Maximum
Trig Source	RF Burst (Wideband)
Burst Sync	Training Sequence

---

**NOTE** Parameters that are under the **Advanced** key seldom need to be changed. Any changes from the default values may result in invalid measurement data.

---

Make sure the Phase and Frequency Error measurement is selected under the **Measure** menu. Press the **Meas Setup** key to access a menu which allows you to modify the averaging, trigger source, and burst sync for this measurement (as described in the “[Measurement Setup](#)” section at the beginning of this chapter).

## Changing the View

The **View/Trace** key will allow you to select the desired view of the measurement from the following:

- **I/Q Error (Quad-View)** - See [Figure 3-4](#). Provides a combination view including:
  - Window 1: Phase Error
  - Window 2: Phase Error with Freq
  - Window 3: RF Envelope
  - Window 4: Numeric Results + Demodulated bits

Any of these windows can be selected (using the **Next Window** key) and made full size (using the **Zoom** key). See [Figure 3-5](#) and [Figure 3-6](#).
- **I/Q Measured Polar Vector** - See [Figure 3-7](#). Provides a view of numeric results and a polar vector graph.
  - Window 1: Numeric Results
  - Window 2: Polar Vector Graph
- **Data Bits** - See [Figure 3-8](#). Provides a view of the numeric results and data bits with the sync word (TSC) highlighted.

The menus under the **Span X Scale** and **Amplitude Y Scale** keys are context dependent upon the selected window (graph type). The **Span X Scale** parameters will be in units of time or bits, dependent on the view selected. The **Amplitude Y Scale** parameters will be in units of dB or degrees, dependent on the view selected. All of the softkey labels are blank when **I/Q Measured Polar Vector**, or **Data Bits** are selected.

## Changing the Display

The **Display** key will allow you to turn the bit dots on and off.

## Troubleshooting Hints

Poor phase error indicates a problem with the I/Q baseband generator, filters, or modulator in the transmitter circuitry. The output amplifier in the transmitter can also create distortion that causes unacceptably high phase error. In a real system poor phase error will reduce the ability of a receiver to correctly demodulate, especially in marginal signal conditions. This ultimately affects range.

Occasionally, a Phase and Frequency Error measurement may fail the prescribed limits at only one point in the burst, for example at the beginning. This could indicate a problem with the transmitter power ramp or some undesirable interaction between the modulator and power amplifier.

## Making the Output RF Spectrum Measurement

### Purpose

The Output RF Spectrum measurement is the EDGE (with GSM) version of adjacent channel power (ACP). Either a single offset is measured with corresponding traces or up to 15 offsets are measured and a table is displayed.

The output RF spectrum measurements determine the spectral energy emitted into the adjacent channels. Excessive amounts of energy spilling into an adjacent frequency channel could interfere with signals being transmitted to other MS or BTS. The measurements are divided into two main groups: spectrum due to the 0.3 GMSK modulation and noise, and spectrum due to switching transients (burst ramping).

Since GSM is a TDMA format, RF power is being switched on and off depending on whether the actual burst is being transmitted. The switching of power causes spectral splatter at frequencies other than that being transmitted by the carrier. Fast transitions in the time domain causes switching transients that have high frequency content associated with them.

---

#### NOTE

The default output RF spectrum measurements do not perform tests at frequency offsets greater than 1800 kHz from the carrier.

---

## Measurement Method

In this measurement, the transmitter (source) is set to transmit a GSM frame at a given channel (frequency). The instrument acquires a time record at a particular offset from the channel being transmitted. The method of acquiring the time record is either a FFT/Inverse-FFT method, or a direct time domain (DTD) method, depending on the offset. These two methods and when they are used, will be described below. When the offset is zero, the instrument is said to be measuring the carrier. For a given offset frequency from the carrier, the transmitter must not exceed a certain power level relative to the carrier. The GSM specification defines the offsets and their maximum absolute and relative power levels.

The general steps in making the measurement are as follows:

- Acquire time record (using either FFT or DTD methods, described below)
- Synchronize for gating on the carrier - finds 50% and 90% portion of burst for Spectrum Due to Modulation portion of the test
- Measure power of the carrier
- Compare each offset power to reference to get relative power level

The method of acquiring the time record is dependent on accuracy and dynamic range. With no pre-ADC filter (infinite bandwidth), the entire IF bandwidth of the IF signal is hitting the analog to digital converter (ADC). The ADC gain is set based on the peak level at its input. The dynamic range (noise floor) of the ADC is dependent on the gain selected. For the type of signals being measured, the highest energy within the IF bandwidth is at the carrier. Therefore, the lowest dynamic range (highest noise floor) of the ADC occurs when the full energy of the carrier is input to the ADC.

All offsets measured using the FFT method are done with the instrument tuned such that the carrier is at the center of the IF bandwidth. Therefore, the dynamic range of the offsets measured using the FFT method is the same as that for the carrier. The dynamic range requirement generally increases as the offset frequency increases. If the dynamic range requirement exceeds what is available by FFT method, the direct time domain (DTD) method utilizing the pre-ADC filter is used.

The **Direct Time Break Freq** key setting is the first offset frequency which is measured using the DTD method. Its range is determined by assuring no aliasing occurs on FFT offsets and that the dynamic range requirements are met.



The FFT method acquires a wideband signal (1.55 MHz) in a flattop filter. An FFT is performed to get the spectrum of the GSM signal. The resolution bandwidth filter can now be applied mathematically to the spectrum at multiple offsets, with an inverse-FFT performed on the data which passes the filter. In this way, multiple offsets are acquired from one time record and LO setting. Since the resolution bandwidth filter is a mathematical formula, it can be any shape and size, and is perfect. The VSA uses the 5-pole synchronously tuned filter that the GSM standard specifies.

The primary disadvantage to the FFT method is that the acquisition must include the carrier. The high energy of the carrier causes the ADC to range down, thus lowering the dynamic range. At large offsets, the dynamic range requirement is very challenging so the direct time domain (DTD) method is used. The LO is tuned to the particular offset and the pre-ADC filter is used to reduce the carrier. This allows the ADC to range up, giving higher dynamic range. The disadvantage to this method is that each offset measured has its own time record acquisition and LO tune position, and this causes the measurement to slow down compared to FFT offsets. The 5-pole synchronously tuned filter is approximated by utilizing a digital Gaussian filter and setting its equivalent noise bandwidth to that of the 5-pole synchronously tuned filter. For these DTD offset frequencies, the filter has closer-to-ideal 5-pole behavior (< 1% tolerance) than does a 10% tolerance, 5-pole analog filter.

Regardless of how the time record is obtained for a particular offset, the power must be measured and compared to the reference power. There are two measurements being made for the test: output RF spectrum due to modulation and the output RF spectrum due to switching transients. The GSM standard specifies which offsets get which tests. In these two modes, the following conditions are met:

- In the output RF spectrum due to modulation measurement, the average value during at least 40 bits between bit 87 and 132 (approximately equivalent to the 50% to 90% portion of the burst, excluding midamble) is retained. The vertical lines mark the section of the burst over which the measurement is made. If multiple bursts are examined, an average of the average values is calculated. The relative power (difference between the average power of the burst at zero offset and the average power of the burst at the indicated offset) and the absolute power are displayed.
- In the output RF spectrum due to switching transients, the peak value of the burst is retained. If multiple bursts are examined, then the maximum of the peak values is retained. The relative power (difference between the peak power of the burst at zero offset and the peak power of the burst at the indicated offset) and the absolute power are displayed.

The GSM standard specifies the tests are run on specified offsets from the carrier. The instrument identifies this as single offset or multiple offset modes. The measurement made in these two modes is the same, except that the multiple offset mode automatically makes the measurement at all the specified offsets frequencies and lists the results in a table at the end of the measurement.

Figure 3-9 shows a single-offset (Examine) trace for an entire GSM frame with timeslots 0, 2, and 6 turned on and timeslots 1, 3, 4, 5, and 7 turned off. The vertical bars show the portion used to measure power due to modulation.

**Figure 3-9** GSM Frame in Single-Offset (Examine)

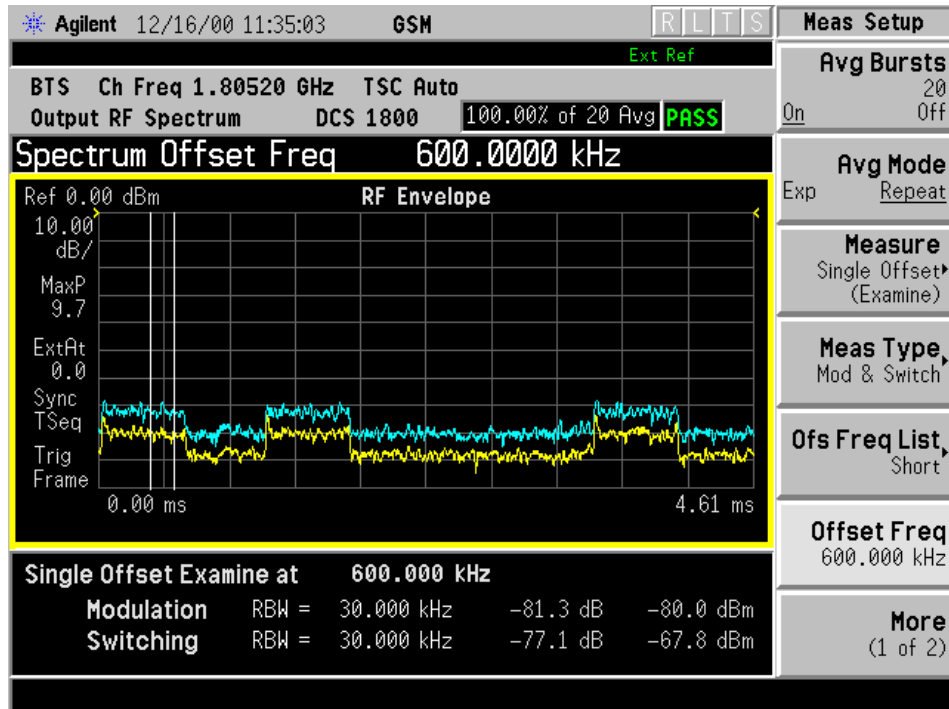

The RF envelope trace is displayed. If averaging is turned on, the trace is then averaged with previous traces. For the modulation measurement, the user may select the type of trace averaging, either log-power averaged (Video) or power averaged (RMS). For the switching transients measurement, the peak of the traces is used. For modulation, the displayed value is the average of points within the vertical bars. For transients, the displayed value is the max of all points (Max of Peak) over the entire frame.

## Making the Measurement

---

NOTE

The factory default settings provide a GSM compliant measurement. For special requirements, you may need to change some of the settings. Press **Meas Setup, More (1 of 2), Restore Meas Defaults** at any time to return all parameters for the current measurement to their default settings.

---

Select the desired ARFCN, center frequency, timeslot, burst type, and TSC (Training Sequence Code) as described in the section titled [“Changing the Frequency Channel” on page 24](#).

When **Training Sequence** is selected as the burst sync for this measurement, set the **Timeslot** selection to determine which timeslot to measure. For example, if **Timeslot** is set to 2, the measurement will be made on the timeslot number 2. Be careful when adding delay in the **Trigger** setup, as this measurement does not take into account trigger delay when checking for a valid burst. If there is sufficient delay added (usually more than 25% of a timeslot), the burst might not be detected.

Press **Measure, Output RF Spectrum** to immediately make Output RF Spectrum the active measurement.

To change any of the measurement parameters from the factory default values, refer to the [“Changing the Measurement Setup”](#) section for this measurement.

## Results

**Figure 3-10** Output RF Spectrum Result Example (Short List) Modulation View

Agilent 12/16/00 10:43:28 GSM						R L T S		Meas Setup	
BTS Ch Freq 1.80520 GHz TSC Auto						Ext Ref		Avg Bursts	
Output RF Spectrum DCS 1800						100.00% of 20 Avg		20	
						PASS		On Off	
<b>Modulation</b>						Ref Power: 1.5 dBm/ 30.000 kHz		Avg Mode	
Offset Freq List: Short						Sync RF A Trig Burst		Exp Repeat	
						Lower Upper		Measure, Multi-Offset	
Offset Freq	Res BW	dB	dBm	dB	dBm				
200.000 kHz	30.000 kHz	-35.9	-34.5	-36.5	-35.1				
250.000 kHz	30.000 kHz	-42.1	-40.6	-41.5	-40.0				
400.000 kHz	30.000 kHz	-65.7	-64.2	-66.5	-65.1				
600.000 kHz	30.000 kHz	-81.0	-79.6	-82.2	-80.7				
1.20000 MHz	30.000 kHz	-84.0	-82.5	-84.2	-82.7				
1.80000 MHz	100.000 kHz	-79.1	-77.6	-79.3	-77.8				
								Meas Type, Mod & Switch	
								Ofs Freq List, Short	
								Offset Freq 400.000 kHz	
								More (1 of 2)	

**Figure 3-11** Output RF Spectrum Result Example (Short List) Switching View

Agilent 12/16/00 10:44:13 GSM						R L T S		Meas Setup	
BTS Ch Freq 1.80520 GHz TSC Auto						Ext Ref		Avg Bursts	
Output RF Spectrum DCS 1800						100.00% of 20 Avg		20	
						PASS		On Off	
<b>Switching</b>						Ref Power: 9.0 dBm/ 300.000 kHz		Avg Mode	
Offset Freq List: Short						Sync RF A Trig Burst		Exp Repeat	
						Lower Upper		Measure, Multi-Offset	
Offset Freq	Res BW	dB	dBm	dB	dBm				
400.000 kHz	30.000 kHz	-64.1	-55.1	-63.5	-54.5				
600.000 kHz	30.000 kHz	-77.4	-68.4	-76.7	-67.7				
1.20000 MHz	30.000 kHz	-80.4	-71.5	-81.3	-72.3				
1.80000 MHz	30.000 kHz	-80.9	-71.9	-81.4	-72.4				
								Meas Type, Mod & Switch	
								Ofs Freq List, Short	
								Offset Freq 400.000 kHz	
								More (1 of 2)	

## Changing the Measurement Setup

**Table 3-4** Output RF Spectrum Measurement Defaults

Measurement Parameter	Factory Default Condition
Avg Bursts	20 On
Avg Mode	Repeat
Meas Method	Multi-Offset
Meas Type	Modulation
Ofs Freq List	Short
Offset Freq (when single offset is selected)	250.000 kHz
Trig Source	RF Burst
Burst Sync (information only)	RF Amptd
Fast Avg	On
<b>Advanced</b>	
Mod Avg	Log-Pwr Avg (Video)
Switching Avg (information only)	Max of Peak
Direct Time Break Freq	600.000 kHz
<b>Modulation Meas BWs</b>	
Carrier RBW	30.000 kHz
<1800 kHz Offset RBW	30.000 kHz
≥1800 kHz Offset RBW	100.000 kHz
VBW/RBW Ratio (information only)	1
<b>Switching Meas BWs</b>	
Carrier RBW	300.000 kHz
<1800 kHz Offset RBW	30.000 kHz
≥1800 kHz Offset RBW	30.000 kHz
VBW/RBW Ratio (information only)	3

---

NOTE

---

Parameters that are under the **Advanced** key seldom need to be changed. Any changes from the default values may result in invalid measurement data.

Make sure the EDGE ORFS measurement is selected under the **Measure** menu. Press the **Meas Setup** key to access a menu which allows you to modify the averaging and trigger source for this measurement (as described in the “[Measurement Setup](#)” section at the beginning of this chapter). In addition, the following output RF spectrum measurement parameters can be modified:

- **Measure** - accesses a menu to choose the measurement mode.
  - Multi-Offset** - automatically makes measurements at all offset frequencies in the selected list (**Standard**, **Short**, or **Custom**). (See table below.) Press the **Ofs Freq List** key to select a list of offsets to measure.
  - Single Offset (Examine)** - makes a measurement at a single offset frequency as set by the **Offset Freq** softkey.
- **Meas Type** - accesses a menu to choose the measurement type.
  - Mod & Switch** - will perform both Modulation and Switching measurements.
  - Modulation** - measures the spectrum due to the 0.3 GMSK modulation and noise.
  - Switching** - measures the spectrum due to switching transients (burst ramping).

- **Ofs Freq List** - accesses a menu to choose the offset frequency list. Select a **Standard**, **Short**, or **Custom** list as shown in the table below.

<b>List</b>	<b>Modulation Offsets (kHz)</b>	<b>Switching Transients Offsets (kHz)</b>
Standard	100, 200, 250, 400, 600, 800, 1000, 1200, 1400, 1600, 1800, 3000, 6000	400, 600, 1200, 1800
Short	200, 250, 400, 600 1200, 1800	400, 600, 1200, 1800
Custom	User-defined list that specifies: Offset Freq, RES BW, Limit Offsets, Meas Type, Initialized to be the same as the standard list  (currently settable only by remote commands)	400, 600, 1200, 1800

- **Offset Freq** - Only available when **Measure** is set to **Single Offset (Examine)**. Offset frequencies can be entered using the RPG knob or the Data Entry keys.
- **Trig Source** - in this measurement, trigger source and burst sync are linked. Refer to the explanation under **Burst Sync**.
- **Burst Sync** - Synchronization is different on ORFS compared to other measurements. Since offsets may be very low power and acquired using very narrow filters, the burst edges are not well defined and there certainly is not enough information to perform a demodulation. Therefore all synchronization is performed on the carrier. The timing reference ("T0") is then re-used on the offsets. Since "T0" on the carrier is determined with respect to the trigger point, the trigger point on the offsets is very important. Once "T0" is determined, the 50% and 90% points can be found.

Therefore, the trigger must be synchronous with respect to a rising edge of a burst. The RF Burst trigger will do this if the offset is within about 7 MHz of the carrier. Remember that since the RF Burst trigger is wideband, the carrier will still cause the signal to trigger. Assuming the trigger threshold remains constant, the trigger with respect to the burst will remain constant. Since the Frame Trigger uses an internal frame timer (clock), its period is set so that it occurs synchronously with respect to the transmitting frame. If an external trigger is used, it is important that it is synchronous with the burst.

Because of these requirements, only the trigger source can be selected while the measurement selects the burst sync type based on the trigger source.

<b>Trigger Source</b>	<b>Measurement Defined Burst Sync</b>
Free Run	None
RF Burst	RF Amplitude
Ext Front	External
Ext Rear	External
Frame	Training Sequence

---

**NOTE**

Video trigger source is not allowed, because when the instrument is tuned to offset frequencies away from the carrier, the video trigger threshold will not be reached (due to the low power level of the offset.)

---



- **Fast Avg** - Fast averaging is a technique developed by HP/Agilent. The GSM standard specifies 50% to 90% portion of the burst, excluding the midamble, be measured. Since most offsets are measured in a 30 kHz filter, there is a lot of variation from burst to burst, hence the averaging.

The fast average method makes use of the 10% to 90% portion of the burst, excluding the midamble. The 10% to 50% portion of the burst has statistically the same average power as the 50% to 90%. Therefore, measuring both portions from one burst is statistically the same as measuring 50% to 90% from two bursts. Now, two averages are completed with one burst. When averaging is turned on, this will double the speed of the measurement.

This method is only applicable on the modulation portion of the test, and only when averaging is enabled. The method is not available when Modulation and Switching are done at the same time.

- **Advanced** - accesses a menu with the following keys:

**Mod Avg** - choose between:

**Pwr Avg (RMS)**

**Log-Pwr Avg (Video)**

**Switching Avg** - information only. Averaging is fixed at maximum of peak.

**Modulation Meas BWs** - accesses a menu with the following selections:

**Carrier RBW**

**<1800 kHz Offset RBW**

**>=1800 kHz Offset RBW**

**VBW/RBW Ratio** - information only. Modulation ratio is fixed at 1.

**Switching Meas BWs** - accesses a menu with the following selections:

**Carrier RBW**

**<1800 kHz Offset RBW**

**>=1800 kHz Offset RBW**

**VBW/RBW Ratio** - information only. Switching ratio is fixed at 3.

**Direct Time Break Freq** - Selects the transition frequency (the first offset frequency) where the Direct Time Domain method is used instead of the FFT method. The Direct Time Domain offers a high dynamic range and is faster for measuring at a few offset frequencies. The FFT method has a moderate dynamic range (generally sufficient when the RBW = 30 kHz). It is much faster for measuring at many offset frequencies

## Changing the View

If the Multi-Offset measurement has been chosen and the Meas Type is Mod & Switch, pressing the **View/Trace** key will allow you to select the desired view of the current measurement. If the Meas Type is Modulation, the **Switching Numeric** view is unavailable. If the Meas Type is Switching, the **Modulation Numeric** view is unavailable.

If the Single Offset measurement has been chosen, the **Modulation Numeric** and the **Switching Numeric** softkeys are unavailable (grayed out) as both modulation and switching results are always displayed.

## Troubleshooting Hints

The Output RF Spectrum measurement, along with the Phase and Frequency Error measurement, can reveal numerous faults in the transmit chain, such as the I/Q baseband generator, filters & modulator.

---

## Making the Spectrum (Frequency Domain) Measurement

---

### NOTE

This Spectrum measurement section is used in the following personalities: Basic, cdmaOne, GSM, NADC, PDC, iDEN, cdma2000, W-CDMA (3GPP), W-CDMA (Trial & Arib).

---

### Purpose

The spectrum measurement provides spectrum analysis capability for the instrument. The control of the measurement was designed to be familiar to those who are accustomed to using swept spectrum analyzers.

This measurement is FFT (Fast Fourier Transform) based. The FFT-specific parameters are located in the **Advanced** menu. Also available under basic mode spectrum measurements is an I/Q window, which shows the I and Q signals in parameters of voltage versus time. The advantage of having an I/Q view available while in the spectrum measurement is that it allows you to view complex components of the same signal without changing settings or measurements.

### Measurement Method

The transmitter tester uses digital signal processing to sample the input signal and convert it to the frequency domain. With the instrument tuned to a fixed center frequency, samples are digitized at a high rate, converted to I and Q components with DSP hardware, and then converted to the frequency domain with FFT software.

### Making the Measurement

---

### NOTE

The factory default parameters provide a good starting point. You will likely want to change some of the settings. Press **Meas Setup, More (1 of 2), Restore Meas Defaults** at any time to return all parameters for the current measurement to their default settings.

---

Press **Measure, Spectrum (Freq Domain)** to immediately make Spectrum (Frequency Domain) the active measurement.

To change any of the measurement parameters from the factory default values, refer to the “Changing the Measurement Setup” section for this measurement.

## Results

A display with both a spectrum window and an I/Q Waveform window will appear when you activate a spectrum measurement. Use the **Next Window** key to select a window, and the **Zoom** key to enlarge a window.

**Figure 3-12** Spectrum Measurement Result- Spectrum and I/Q Waveform

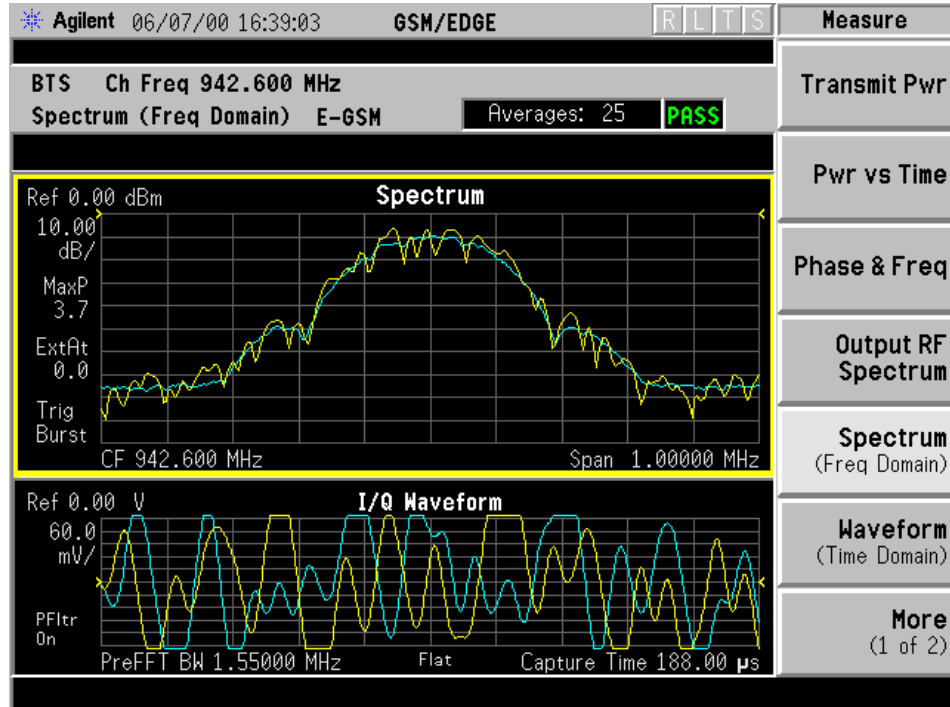

## Changing the Measurement Setup

**Table 1** Spectrum (Frequency Domain) Measurement Defaults

Measurement Parameter	Factory Default Condition
Res BW	
Averaging:	
Avg Number	25 On
Avg Mode	Exp
Avg Type	Log-Pwr Avg (Video)
Trigger Source	
Measurement Time (Service mode only)	1.0 ms (Auto)
<b>Spectrum Window:</b>	
Span	
Scale/Div - Amplitude Y Scale	10.00 dB
<b>I/Q Waveform Window:</b>	
Capture Time	
Scale/Div - Amplitude Y Scale	60 mV
<b>Advanced</b>	
Pre-ADC BPF	On
Pre-FFT Filter	Flat
Pre-FFT BW	
FFT Window	Flat Top (High AmptdAcc)
FFT Size:	
Length Control	Auto
Min Points/RBW	1.300000
Window Length	
FFT Length	
ADC Range	Auto Peak
Data Packing	Auto
ADC Dither	Auto
Decimation	0 (Auto)
IF Flatness	On

---

NOTE

---

Parameters under the **Advanced** key seldom need to be changed. Any changes from the default advanced values may result in invalid measurement data.

Make sure the **Spectrum (Freq Domain)** measurement is selected under the **Measure** menu. Press the **Meas Setup** key to access a menu which allows you to modify the averaging, and trigger source for this measurement (as described in the “Measurement Setup” section). In addition, the following parameters can be modified:

- **Span** - This key allows you to modify the frequency span. Changing the span causes the bandwidth to change automatically, and will affect data acquisition time.
- **Res BW** - This feature sets the resolution bandwidth for the FFT, and allows manual or automatic settings. A narrower bandwidth will result in a longer data acquisition time. In Auto mode the resolution bandwidth is set to Span/50 (2% of the span).
- **Advanced** - The following FFT advanced features should be used only if you are familiar with their operation. Changes from the default values may result in invalid data.

**Pre-ADC BPF** - This key allows you to toggle the pre-ADC bandpass filter to On or Off states. The pre-ADC bandpass filter is useful for rejecting nearby signals, so that sensitivity within the span range can be improved by increasing the ADC range gain.

**Pre-FFT Fltr** - Allows you to toggle between **Flat** (flat top) and **Gaussian**. The pre-FFT filter defaults to a flat top filter which has better amplitude accuracy. The Gaussian filter has better pulse response.

**Pre-FFT BW** - The Pre-FFT bandwidth allows you to select between a manual or an automatic setting. The pre FFT-bandwidth filter can be set between 1 Hz and 10 MHz. In Auto mode this bandwidth is nominally 50% wider than the span. This bandwidth determines the ADC sampling rate.

**FFT Window** - Allows you to access the following selection menu. Unless you are familiar with FFT windows, use the flat top filter (the default filter).

- **Flat Top** - Selects a filter for best amplitude accuracy, by reducing scalloping error.
- **Uniform** - You can select to have no window active by using the uniform setting.
- **Hanning**
- **Hamming**
- **Gaussian** - Selects a gaussian filter with an alpha of 3.5.
- **Blackman**
- **Blackman Harris**
- **K-B 70dB / 90dB/ 110dB (Kaiser-Bessel)** - Allows selection of Kaiser-Bessel filters with sidelobes of -70, -90, or -110 dBc.

**FFT Size** - This menu contains the following features:

- **Length Ctrl** - This feature allows you to set the FFT and window lengths either automatically or manually.
- **Min Pts in RBW** - This feature allows you to set the minimum number of data points that will be used inside the resolution bandwidth. This adjustment is only available if the **Length Ctrl** key is set to Auto.
- **Window Length** - This feature allows you to enter the FFT window length ranging from 8 to 1048576. This length represents the actual quantity of I/Q samples that are captured for processing by the FFT. This value can only be entered if length control is set to Manual.
- **FFT Length** - This feature allows you to enter the FFT length in the number of captured samples, ranging from 4096 to 1048576. The FFT length setting is automatically limited so that it is equal or greater than the FFT window length setting. Any amount greater than the window length is implemented by zero-padding. This value can be entered only if length control is set to Man (manual).

**ADC Range** - Allows you to access the following selection menu to define one of the following ADC ranging functions:

- **Auto** - Select this to set the ADC range automatically. For most FFT spectrum measurements, the auto feature should not be selected. An exception is when measuring a signal which is “bursty”, in which case auto can maximize the time domain dynamic range, if FFT results are less important to you than time domain results.
- **Auto Peak** - Select this to set the ADC range automatically to the peak signal level. Auto peak is a compromise that works well for both CW and burst signals.
- **AutoPeakLock** - Select this to hold the ADC range automatically at the peak signal level. Auto peak lock is more stable than auto peak for CW signals, but should not be used for “bursty” signals.
- **Manual** - Allows you to access the selection menu: **-6 dB, 0 dB, +6 dB, +12 dB, +18 dB, +24 dB**, to set the ADC range level. Also note that manual ranging is best for CW signals.

**Data Packing** - Allows you to access the following selection menu to define one of the following data packing methods:

- **Auto** - Data is automatically packed. This is the default setting and most recommended.
- **Short (16 bit)** - Data is packed by every 16 bits.
- **Medium (24 bit)** - Data is packed by every 24 bits.
- **Long (32 bit)** - Data is packed by every 32 bits.

**ADC Dither** - Allows you to toggle the ADC dither function between **Auto, On, and Off**. When set to auto (the default), ADC dither will be activated when a narrow bandwidth is being measured, and deactivated when a wide bandwidth is being measured. “ADC dither” refers to the introduction of noise to the digitized steps of the analog-to-digital converter; the result is an improvement in amplitude accuracy. Use of the ADC dither, however, reduces dynamic range by approximately 3 dB.



**Decimation** - Allows you to toggle the decimation function between **Auto** and **Man**, and to set the decimation value. **Auto** is the preferred setting, and the only setting that guarantees alias-free FFT spectrum measurements. If you are familiar with the decimation feature, you can change the decimation value by setting to **Man**, but be aware that aliasing can result in higher values.

**IF Flatness** - Allows you to toggle between **On** and **Off**. When toggled to **On** (the default), the IF flatness feature causes background amplitude corrections to be performed on the FFT spectrum. The **Off** setting is used for adjustment and troubleshooting the transmitter tester.

## Changing the View

View/Trace menu keys are used to activate a view of a measurement with preset X and Y scale parameters, called a “window”. Using the X and Y Scale keys you can then modify these parameter settings. You can also activate specific traces, using the **Trace Display** menu key.

### Windows Available for Spectrum Measurements

The spectrum and the I/Q windows can be viewed at the same time, or individually. You can use the **Next Window** and **Zoom** keys to move between these different views.

**Spectrum window** Select this window if you want to view frequency and power. Changes to frequency span or power will sometimes affect data acquisition.

**I/Q Waveform window.** Select this window to view the I and Q signal characteristics of the current measurement in parameters of voltage and time.

---

NOTE

For the widest spans the I/Q window becomes just “ADC time domain samples”, because the I/Q down-conversion is no longer in effect.

---

## Using the Markers

The **Marker** front-panel key accesses the menu to configure the markers. If you want to use the marker function in the I/Q window, press **View/Trace, I/Q Waveform, Marker, Trace, IQ Waveform**.

- **Select 1 2 3 4** - Allows you to activate up to four markers with the corresponding numbers, respectively. The selected number is underlined and its function is defined by pressing the **Function** key. The default is 1.
- **Normal** - Allows you to activate the selected marker to read the frequency and amplitude of the marker position on the spectrum trace, for example, which is controlled by the **RPG** knob.
- **Delta** - Allows you to read the differences in frequencies and amplitudes between the selected marker and the next.
- **Function Off** - Allows you to define the selected marker function to be **Band Power, Noise, or Off**. The default is **Off**. If set to **Band Power**, you need to select **Delta**.
- **Trace Spectrum** - Allows you to place the selected marker on the **Spectrum, Spectrum Avg, or I/Q Waveform** trace. The default is **Spectrum**.
- **Off** - Allows you to turn off the selected marker.
- **Shape Diamond** - Allows you to access the menu to define the selected marker shape to be a **Diamond, Line, Square, or Cross**. The default is a **Diamond**.
- **Marker All Off** - Allows you to turn off all of the markers.

The front panel **Search** key performs a peak search when pressed. A marker will automatically be activated at the highest peak.

## Band Power

A band power measurement using the markers calculates the average power between two adjustable markers. To make a band power measurement:

Press the **Marker** key.

Press **Trace, Spectrum** to activate a marker on the instantaneous spectrum signal. Press the **Spectrum Avg** key to activate a marker on the average spectrum trace.

Press **Function, Band Power**.

Two marker lines are activated at the extreme left side of the horizontal scale. Press **Normal** and move marker 1 to the desired place by rotating the **RPG** knob.

Press **Delta** to bring marker 2 to the same place as marker 1.

Move marker 1 to the other desired position by rotating the **RPG** knob. Band power measures the average power between the two markers. When the band power markers are active, the results are shown in the results window as Mean Pwr (Between Mks). When the band power function is off the results window reads Mean Pwr (Entire Trace).

## Troubleshooting Hints

Changes made by the user to advanced spectrum settings, particularly to ADC range settings, can inadvertently result in spectrum measurements that are invalid and cause error messages to appear. Care needs to be taken when using advanced features.

## Making the Waveform (Time Domain) Measurement

---

### NOTE

This Waveform measurement section is used in the following personalities: Basic, cdmaOne, GSM, NADC, PDC, iDEN, cdma2000, W-CDMA (3GPP), W-CDMA (Trial & Arib).

---

### Purpose

The waveform measurement is a generic measurement for viewing waveforms in the time domain. This measurement is how the instrument performs the zero span functionality found in traditional spectrum analyzers. Also available under basic mode waveform measurements is an I/Q window, which shows the I and Q signal in parameters of voltage and time. The advantage of having an I/Q view available while in the waveform measurement is that it allows you to view complex components of the same signal without changing settings or measurements.

The waveform measurement can be used to perform general purpose power measurements to a high degree of accuracy.

### Measurement Method

The transmitter tester makes repeated power measurements at a set frequency, similar to the way a swept-tuned spectrum analyzer makes zero span measurements. The input analog signal is converted to a digital signal, which then is processed into a representation of a waveform measurement. The transmitter tester relies on a high rates of sampling to create an accurate representation of a time domain signal.

### Making the Measurement

---

### NOTE

The factory default parameters provide a good starting point. You will likely want to change some of the settings. Press **Meas Setup, More (1 of 2), Restore Meas Defaults** at any time to return all parameters for the current measurement to their default settings.

---

Press **Measure, Waveform (Time Domain)** to immediately make Waveform (Time Domain) the active measurement.

To change any of the measurement parameters from the factory default values, refer to the “Changing the Measurement Setup” section for this measurement.

## Results

Figure 3-13

### Waveform Measurement Results- RF Envelope Window

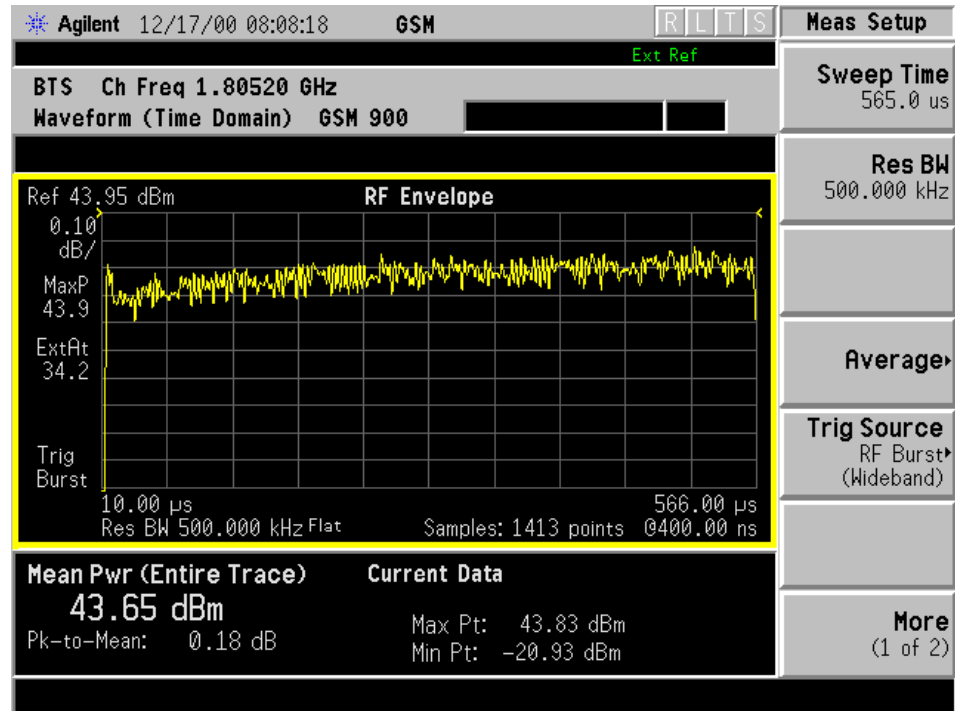

## Changing the Measurement Setup

**Table 2** Waveform (Time Domain) Measurement Defaults

Measurement Parameter	Factory Default Condition
View/Trace	RF Envelope
Sweep Time	
Res BW	
Averaging:	
Avg Number	10 Off
Avg Mode	Exp
Avg Type	Pwr Avg (RMS)
Trigger Source	
<b>RF Envelope Window:</b>	
Amplitude Y Scale	
Scale/Div	10.00 dB
Reference	0.00 dBm (Top)
<b>I/Q Waveform Window:</b>	
Amplitude Y Scale	
Scale/Div	100.0 mv
Reference	0.00 V (Ctr)
<b>Advanced</b>	
Pre-ADC BPF	Off
RBW Filter	Gaussian
ADC Range	Auto
Data Packing	Auto
ADC Dither	Off
Decimation	Off

---

**NOTE** Parameters that are under the **Advanced** key seldom need to be changed. Any changes from the default values may result in invalid measurement data.

---

Make sure the **Waveform (Time Domain)** measurement is selected under the **Measure** menu. Press the **Meas Setup** key to access a menu which allows you to modify the averaging, and trigger source for this measurement (as described in the “Measurement Setup” section). In addition, the following parameters can be modified:

- **Sweep Time** - This key allows you to select the measurement acquisition time. It is used to specify the length of the time capture record. Values between 10  $\mu$ s and 50 s can be entered, depending upon the resolution bandwidth setting.
- **Res BW** - This key sets the measurement bandwidth. A larger bandwidth results in a larger number of acquisition points and reduces the maximum allowed for sweep time. You can enter values between 10 Hz. and 7.5 MHz.
- **Advanced** menu key. This key accesses the features listed below.

**Pre-ADC BPF** - This key allows you to toggle the pre-ADC bandpass filter to On or Off states. The pre-ADC bandpass filter is useful for rejecting nearby signals, so that sensitivity within the span range can be improved by increasing the ADC range gain

**RBW Filter** - This key toggles to select a flat top or a Gaussian resolution bandwidth filter. A Gaussian filter provides more even time domain response, particularly for bursts. A flat top filter provides a flatter bandwidth but is less accurate for pulse responses. A flat top filter also requires less memory and allows longer data acquisition times. For most waveform applications, the Gaussian filter is recommended, and it is the default filter for waveform measurements.

**ADC Range** -.Allows you to access the following selection menu to define one of the following ADC ranging functions:

- **Auto** - This key causes the instrument to automatically adjust the signal range for optimal measurement results.
- **AutoPeak** - This key causes the instrument to continuously seek the highest peak signal.
- **AutoPeakLock** - This key causes the instrument to adjust the range for the highest peak signal it identifies, and retains the range settings determined by that peak signal, even when the peak signal is no longer present.
- **Manual** - Allows you to access the selection menu: **-6 dB, 0 dB, +6 dB, +12 dB, +18 dB, +24 dB**, to set the ADC range level. Also note that manual ranging is best for CW signals.

**Data Packing** - Allows you to access the following selection menu to define one of the following data packing methods:

- **Auto** - Data is automatically packed. This is the default setting and most recommended.
- **Short (16 bit)** - Data is packed by every 16 bits.
- **Medium (24 bit)** - Data is packed by every 24 bits.
- **Long (32 bit)** - Data is packed by every 32 bits.

**ADC Dither** - Allows you to toggle the ADC dither function between **On** and **Off**. Activation of the ADC dither results in better amplitude linearity and resolution in low level signals. However, it also results in reduced dynamic range. ADC dither is set to **Off** by default.

**Decimation** - Allows you to toggle the decimation function between **On** and **Off** and to set the decimation value. Decimation allows longer acquisition times for a given bandwidth by eliminating data points. Long time captures can be limited by the transmitter tester data acquisition memory. Decimation numbers 1 to 4 describe the factor by which the number of points are reduced. A decimation figure of 1, which results in no data point reduction, is the default.



## Changing the View

The **View/Trace** menu keys are used to activate a view of a measurement with preset X and Y scale parameters; this view is called a “window.” Using the X and Y scale keys, you can then modify these parameters. You can also activate traces, using the **Traces Display** menu key.

### Windows Available for Waveform Measurements

**RF Envelope window.** Select this window if you want to view power (in dBm) vs. time. Remember that data acquisition will be affected when you change the sweep time.

**I/Q Waveform window.** Select this window to view the I and Q signal characteristics of the current measurement in parameters of voltage and time.

## Using the Markers

The **Marker** front-panel key accesses the menu to configure the markers. If you want to use the marker function in the I/Q window, press **View/Trace, I/Q Waveform, Marker, Trace, IQ Waveform.**

- **Select 1 2 3 4** - Allows you to activate up to four markers with the corresponding numbers, respectively. The selected number is underlined and its function is defined by pressing the **Function** key. The default is 1.
- **Normal** - Allows you to activate the selected marker to read the frequency and amplitude of the marker position on the spectrum trace, for example, which is controlled by the **RPG** knob.
- **Delta** - Allows you to read the differences in frequencies and amplitudes between the selected marker and the next.
- **Function Off** - Allows you to define the selected marker function to be **Band Power, Noise, or Off**. The default is **Off**. If set to **Band Power**, you need to select **Delta**.
- **Trace Spectrum** - Allows you to place the selected marker on the **Spectrum, Spectrum Avg, or I/Q Waveform** trace. The default is **Spectrum**.
- **Off** - Allows you to turn off the selected marker.
- **Shape Diamond** - Allows you to access the menu to define the selected marker shape to be a **Diamond, Line, Square, or Cross**. The default is a **Diamond**.
- **Marker All Off** - Allows you to turn off all of the markers.

The front panel **Search** key performs a peak search when pressed. A marker will automatically be activated at the highest peak.

---

**NOTE**

In the Waveform measurement, the Mean Pwr (Entire Trace) value plus the Pk-to-Mean value will sum to equal the current Max Pt. value as shown in the data window below the RF Envelope display. If you do a marker peak search (**Search**) with averaging turned off, the marker will find the same maximum point. However, if you turn averaging on, the Pk-to-Mean value will use the highest peak found for any acquisition during averaging, while the marker peak will look for the peak of the display, which is the result of n-averages. This will usually result in differing values for the maximum point.

---

### **Band Power**

A band power measurement using the markers calculates the average power between two adjustable markers. To make a band power measurement:

Press the **Marker** key.

Press **Function, Band Power**.

Two marker lines are activated at the extreme left side of the horizontal scale. Press **Normal** and move marker 1 to the desired place by rotating the **RPG** knob.

Press **Delta** to bring marker 2 to the same place as marker 1.

Move marker 1 to the other desired position by rotating the **RPG** knob. Band power measures the average power between the two markers. When the band power markers are active, the results are shown in the results window as Mean Pwr (Between Mks). When the band power function is off the results window reads Mean Pwr (Entire Trace).

### **Troubleshooting Hints**

Changes made by the user to advanced waveform settings can inadvertently result in measurements that are invalid and cause error messages to appear. Care needs to be taken when using advanced features.

## Making the Tx Band Spur Measurement

### Purpose

The Tx Band Spur measurement checks that the transmitter does not transmit undesirable energy into the transmit band. This energy may cause interference for other users of the GSM system.

### Measurement Method

This is a base station only measurement. The transmitter should be set at its maximum output power on all time slots. This measurement is performed at RF channels B (bottom), M (middle), and T (top). Refer to the following table.

Band	Tx Band Edge (MHz)		BOTTOM		MIDDLE		TOP	
	Low	High	Freq (MHz)	ARFCN	Freq (MHz)	ARFCN	Freq (MHz)	ARFCN
P-GSM	935	960	935.200	1	947.600	63	959.800	124
E-GSM	925	960	925.200	975	942.600	38	959.800	124
R-GSM	921	960	921.200	955	940.600	28	959.800	124
DCS 1800	1805	1880	1805.20	512	1842.60	699	1879.80	885
PCS 1900	1930	1990	1930.20	512	1960.00	661	1989.80	810
GSM 450	460.4	467.6	460.600	259	464.000	276	467.400	293
GSM 480	488.8	496.0	489.000	306	492.400	323	495.800	340
GSM 850	869	894	869.200	128	881.600	190	893.800	251

The transmit band spectrum is measured in several frequency segments using resolution bandwidths as specified by the standard (see the list below).

Frequency Offset	Resolution Bandwidth
≥ 1.8 MHz and < 6 MHz and inside Tx band	30 kHz
≥ 6 MHz and inside Tx band	100 kHz

The mean transmit power is measured first using the “power-above-threshold” method (see the Transmit Power measurement for detail), and then used as a reference for the measurement limit lines if limits are used. The spectrums, which are below or above the carrier frequency and within the transmit band, are measured.

For each spectrum segment, the measurement looks for the spectrum peak closest to the limit and saves the data. The peak of all segments is reported as the *Worst Spur*. The amplitude difference from the peak to the limit line ( $\Delta$  from Limit), and from the peak to the mean transmit power ( $\Delta$  from Carrier) are displayed. The frequency difference from the peak to the carrier frequency (Offset Freq) is also displayed. If the peak goes above the limit line, the display will indicate *FAIL*. If Marker is on, the active marker is placed at the peak of the displayed segment.

## Making the Measurement

---

### NOTE

The factory default settings provide a GSM compliant measurement. For special requirements, you may need to change some of the settings. Press **Meas Setup, More (1 of 2), Restore Meas Defaults** at any time to return all parameters for the current measurement to their default settings.

---

Select the desired transmit band, (P-GSM, E-GSM, R-GSM, GSM 450, GSM 480, GSM 850, DCS 1800, or PCS 1900), as described in the section “[Changing the Mode Setup](#)” on page 18. Select the desired ARFCN and center frequency as described in the section “[Changing the Frequency Channel](#)” on page 24.

Press **Measure, Tx Band Spur** to immediately make Tx Band Spur the active measurement.

To change any of the measurement parameters from the factory default values, refer to the “[Changing the Measurement Setup](#)” section for this measurement.

## Results

**Figure 3-14 Tx Band Spur - Lower Segment**

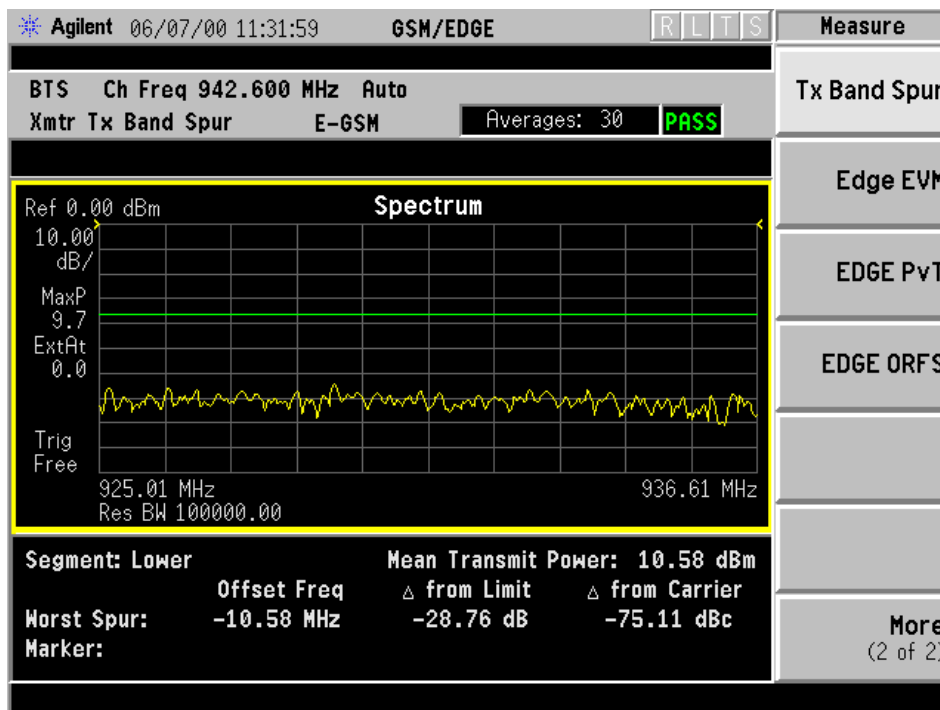

## Changing the Measurement Setup

**Table 3-5 Tx Band Spur Measurement Defaults**

Measurement Parameter	Factory Default Condition
Avg Number	30 On
Avg Mode	Repeat
Avg Type	Maximum
Meas Type	Full
Limit	-36 dBm

Make sure the Tx Band Spur measurement is selected under the **Measure** menu. The **Meas Setup** key will access a menu which allows you to modify the averaging for this measurement. The following Tx Band Spur measurement parameters can be modified:

- **Meas Type** - select the measurement type from the following selections:
  - Full** - In Continuous Measure, it repeatedly does full search of all segments.
  - Examine** - In Continuous Measure, after doing one full search across all segments, it parks on the worst segment and continuously updates that segment.
- **Limit** - set the absolute or relative limit. The limit range is from -200 dBm to 100 dBm.
  - dBm** - Absolute limit
  - dBc** - Relative to Mean Transmit Power.

## Changing the View

The **View/Trace** key will allow you to further examine the desired spectrum segment. Each of these choices selects a different part of the frequency spectrum for viewing:

<b>Lower Segment</b>	lower Tx band edge to -6 MHz offset from the channel frequency
<b>Lower Adj Segment</b>	-6 MHz to -1.8 MHz offset from the channel frequency
<b>Upper Adj Segment</b>	+1.8 MHz to +6 MHz offset from the channel frequency
<b>Upper Segment</b>	+6 MHz offset from the channel frequency to the upper Tx band edge

## Troubleshooting Hints

Almost any fault in the transmitter circuits can manifest itself as spurious of one kind or another. Make sure the transmit band is correctly selected and the frequency is either the Bottom, Middle, or Top channel. The “Unexpected carrier frequency (BMT only)” message usually indicates the transmit band and/or carrier frequency is not correct. The “ADC overload -- unexpected carrier frequency” message usually indicates the channel frequency of the VSA does not match the carrier frequency of the signal.

## Making the EDGE EVM Measurement

### Purpose

Phase and frequency errors are the measures of modulation quality for the EDGE (with GSM) system. Since the EDGE (with GSM) system uses the  $3\pi/8$  8PSK modulation technique, the phase and frequency accuracies of the EDGE (with GSM) transmitter are critical to the communications system performance and ultimately affect range.

EDGE (with GSM) receivers rely on the phase and frequency quality of the  $3\pi/8$  8PSK modulation signal in order to achieve the expected carrier to noise ratio. A transmitter with high phase and frequency errors will often still be able to support phone calls during a functional test. However, it will tend to provide difficulty for mobiles trying to maintain service at the edge of the cell with low signal levels or under difficult fading and Doppler conditions.

### Measurement Method

The phase error of the unit under test is measured by computing the difference between the phase of the transmitted signal and the phase of a theoretically perfect signal.

The instrument samples the transmitter output in order to capture the actual phase trajectory. This is then demodulated and the ideal phase trajectory is mathematically derived. Subtracting one from the other results in an error signal.

This measurement allows you to display these errors numerically and graphically on the instrument display. There are graphs for EVM, Phase Error and Mag Error in the graph windows. In the text window, there are Evm: in % rms, in % peak at the highest symbol number, 90 % EVM result, Mag Error: in % rms, Phase Error: in degrees, Freq Error: in Hz, Droop in mdB/symbol, and I/Q Offset: in dB.

## Making the Measurement

**NOTE**

The factory default settings provide an EDGE compliant measurement. For special requirements, you may need to change some of the settings. Press **Meas Setup, More (1 of 2), Restore Meas Defaults** at any time to return all parameters for the current measurement to their default settings.

Select the desired center frequency, burst type, and slot as described in “Radio” on page 18.

Press **Measure, EVM** to immediately make the error vector magnitude measurement.

To change any of the measurement parameters from the factory default values, refer to “Changing the Measurement Setup” for this measurement.

## Results

The next figure shows an example of measurement result with the graphic and text windows. The measured summary data is shown in the left window and the dynamic vector trajectory of the I/Q demodulated signal is shown as a polar vector display in the right window.

**Figure 3-15 Error Vector Magnitude Measurement - Polar Vector View**

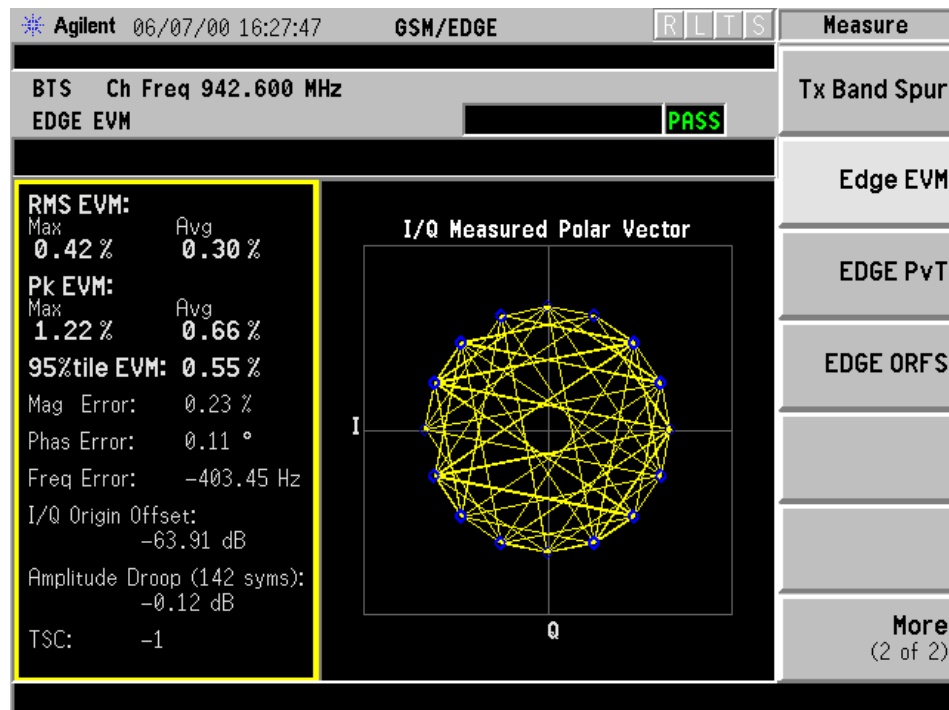



## Changing the Measurement Setup

The next table shows the factory default settings for error vector magnitude measurements.

**Table 3-6 Error Vector Magnitude Measurement Defaults**

Measurement Parameter	Factory Default Condition
Avg Number	10, On
Avg Mode	Exponential
Trigger Source	RF Burst (Wideband)
Burst Sync	RF Amptd
View/Trace	I/Q Measured Polar Vector
Limit Test	On
Limits: RMS EVM	12.5%
Limits: Peak EVM	40.0%
Limits: Origin Offset	-20 dB

Make sure the **Error Vector Magnitude (EVM)** measurement is selected under the **Measure** menu. The **Meas Setup** key accesses a menu which allows you to modify the averaging, trigger source and burst sync for this measurement as described in “[Measurement Setup](#)” earlier in this chapter. However, the trigger source does not include **Line**.

## Changing the View

The **View/Trace** key accesses the menu which allows you to select the desired measurement view from the following selections:

- **I/Q Measured Polar Vector** - The measured summary data is shown in the left window and the dynamic vector trajectory of I/Q demodulated signal is shown as a polar vector display in the right window, as shown in [Figure 3-15 on page 104](#).
- **I/Q Measured Polar Constln** - The measured summary data is shown in the left window and the dynamic vector constellation of I/Q demodulated signal is shown as a polar vector display in the right window as shown in [Figure 3-16 on page 106](#).

**Figure 3-16 Error Vector Magnitude Measurement - Polar Constln**

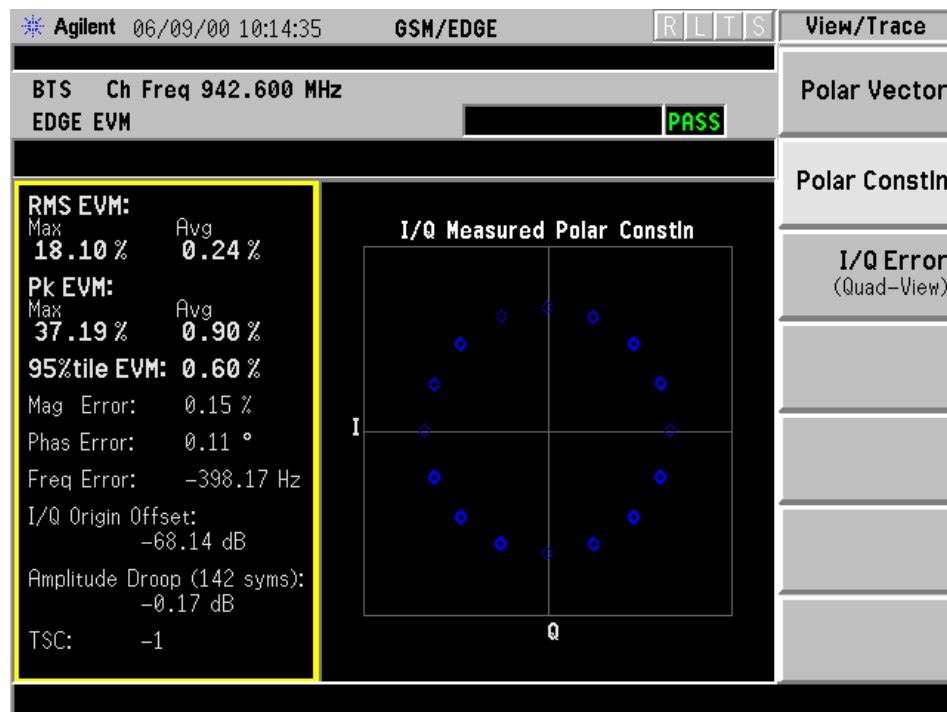

- **I/Q Error (Quad-View)** - Four display windows show EVM, Mag Error and Phase Error graphs, and the EVM summary data text.

**Figure 3-17 Error Vector Magnitude Measurement - Quad View**

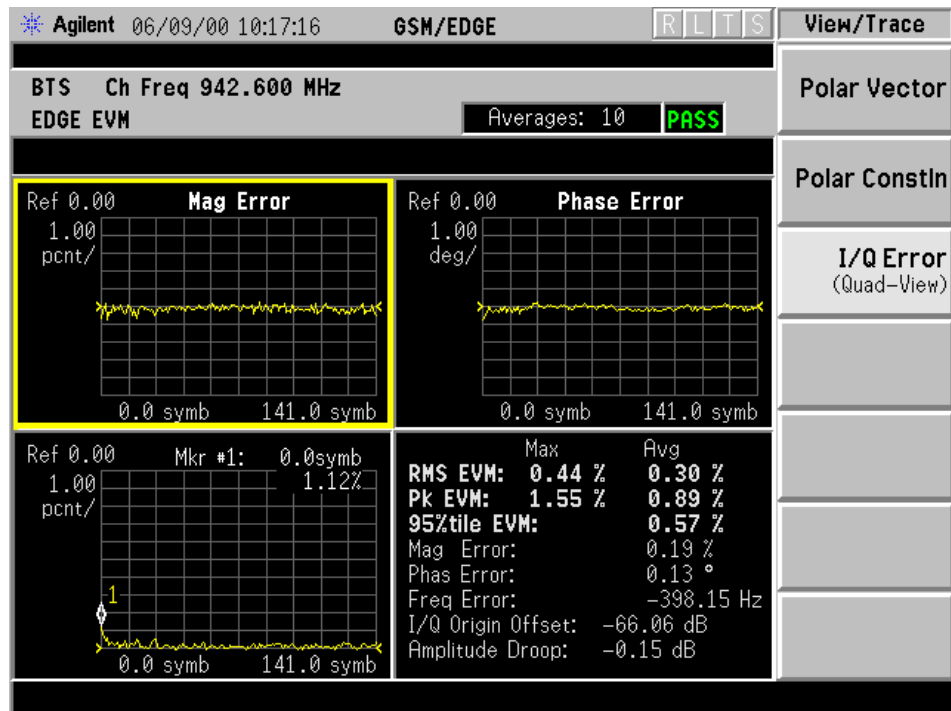

### Changing the Display

The **Display** key accesses the menu to allow the following selections for changing the graph displays:

- **Symbol Dots** - Allows you to toggle the symbol dots between **On** and **Off**. The default setting is **On**.

When either EVM, Phase Error or Mag Error window is active in the I/Q Error (Quad-View) display, the **Span X Scale** key accesses the menu to allow the following selections:

- **Scale/Div** - Allows you to define the horizontal scale by changing the symbol value per division. The range is 1 to 100 symbols per division. The default setting is 13.7 (for BS) or 13.4 (for MS) symbols per division.
- **Ref Value** - Allows you to set the symbol reference value ranging from 0 to 1000 symbols. The default setting is 0.
- **Ref Position** - Allows you to set the reference position to either **Left**, **Ctr** (center) or **Right**. The default setting is **Left**.

- **Scale Coupling** - Allows you to toggle the scale coupling function between **On** and **Off**. The default setting is **On**. This function automatically determines the scale per division and reference value by the magnitude of the measurement results.

When either **EVM:** or **Mag Error:** window is active in the I/Q Error (Quad-View) display, the **Amplitude Y Scale** key accesses the menu to allow the following selections:

- **Scale/Div** - Allows you to define the vertical scale by changing the value per division. The range is 0.01 to 3600 degrees. The default setting is 20.0 degrees per division. However, since the **Scale Coupling** default is set to **On**, this value is automatically determined by the measurement results.
- **Ref Value** - Allows you to set the reference value ranging from 0 to 500%. The default setting is 0%.
- **Ref Position** - Allows you to set the reference position to either **Top**, **Ctr** (center) or **Bot** (bottom). For the **EVM:** graph the, default setting is **Bot**. For the **Mag Error:** graph the default setting is **Ctr**.
- **Scale Coupling** - Allows you to toggle the scale coupling function between **On** and **Off**. The default setting is **On**. This function automatically determines the scale per division and reference value by the magnitude of the measurement results.

When the **Phase Error:** window is active in the I/Q Error display, the **Amplitude Y Scale** key accesses the menu to allow the following selections:

- **Scale/Div** - Allows you to define the vertical scale by changing the value per division. The range is 0.01 to 3600 degrees. The default setting is 20.0 degrees per division. However, since the **Scale Coupling** default is set to **On**, this value is automatically determined by the measurement results.
- **Ref Value** - Allows you to set the reference value ranging from 0 to 500%. The default setting is 0%.
- **Ref Position** - Allows you to set the reference position to either **Top**, **Ctr** (center) or **Bot** (bottom). For the **EVM** graph, the default setting is **Bot**. For the **Mag Error** graph, the default setting is **Ctr**.
- **Scale Coupling** - Allows you to toggle the scale coupling function between **On** and **Off**. The default setting is **On**. This function automatically determines the scale per division and reference value by the magnitude of the measurement results.

## **Troubleshooting Hints**

Use the spectrum (frequency domain) measurement to verify that the signal is present and approximately centered on the display.

Poor phase error indicates a problem at the I/Q baseband generator, filters, and/or modulator in the transmitter circuitry. The output amplifier in the transmitter can also create distortion that causes unacceptably high phase error. In a real system, poor phase error will reduce the ability of a receiver to correctly demodulate the signal, especially in marginal signal conditions.

## Making the EDGE PvT Measurement

### Purpose

EDGE PvT measures the mean transmit power during the “useful part” of GSM bursts and verifies that the power ramp fits the within the defined mask. Power vs. Time also lets you view the rise, fall, and “useful part” of the GSM burst.

GSM is a Time Division Multiple Access (TDMA) scheme with eight time slots, or bursts, per RF channel. If the burst does not occur at exactly the right time, or if the burst is irregular, then other adjacent timeslots can experience interference. Because of this, the industry standards specify a tight mask for the fit of the TDMA burst.

The Power vs. Time measurement provides masks for both BTS (Base Transceiver Station) and MS (mobile station). The timings are referenced to the transition from bit 13 to bit 14 of the midamble training sequence. The 0 dB reference is determined by measuring the mean transmitted power during the “useful part” of the burst. You can also define a user configurable limit mask to apply to the measured burst (refer to the [“Changing the Measurement Setup”](#) section).

The GSM specifications defines the “useful part” of the normal GSM burst as being the 147 bits centered on the transition from bit 13 to bit 14 (the “T0” time point).

### Measurement Method

The instrument acquires a GSMEDGE (with GSM) signal in the time domain. The “T0” point and the useful part are computed. If Burst Sync is set to **Training Seq**, a GSM demodulation is performed to find “T0”. If Burst Sync is set to **RF Amptd**, an approximation of “T0” will be used without performing a demodulation. The average power in the useful part is then computed and displayed, and the GSM limit mask is applied. The measurement displays `PASS` when the burst fits within the bounds of the mask.

## Making the Measurement

---

NOTE

The factory default settings provide a GSMEDGE (with GSM) compliant measurement. For special requirements, you may need to change some of the settings. Press **Meas Setup, More (1 of 2), Restore Meas Defaults** at any time to return all parameters for the current measurement to their default settings.

---

Select the desired ARFCN, center frequency, timeslot, burst type, and TSC (Training Sequence Code) as described in the section titled [“Changing the Frequency Channel” on page 24](#).

**Timeslot** is available when **Burst Sync** is either **Training Sequence** or **RF Amptd**.

The timeslots are determined by taking the acquired data and dividing it into timeslots 0 to 7. An active timeslot burst must be within approximately 25% of the expected timeslot position, otherwise the E4406A may think the burst is an adjacent timeslot and may not detect it. The trigger delay can be used to position the signal if it is not aligning in the timeslots as desired.

Press **Measure, Pwr vs Time** to immediately make Power vs. Time the active measurement.

To change any of the measurement parameters from the factory default values, refer to the [“Changing the Measurement Setup”](#) section for this measurement.

## Results

**Figure 3-18** Power vs. Time Measurement Result - Burst View

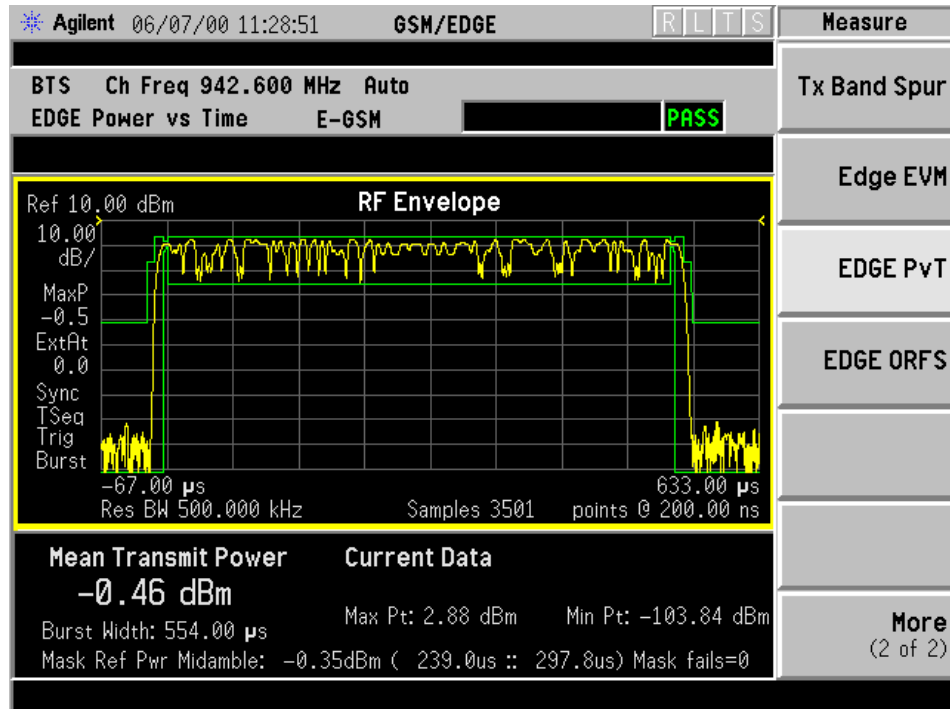

**Figure 3-19** Power vs. Time Measurement Result - Rise & Fall View

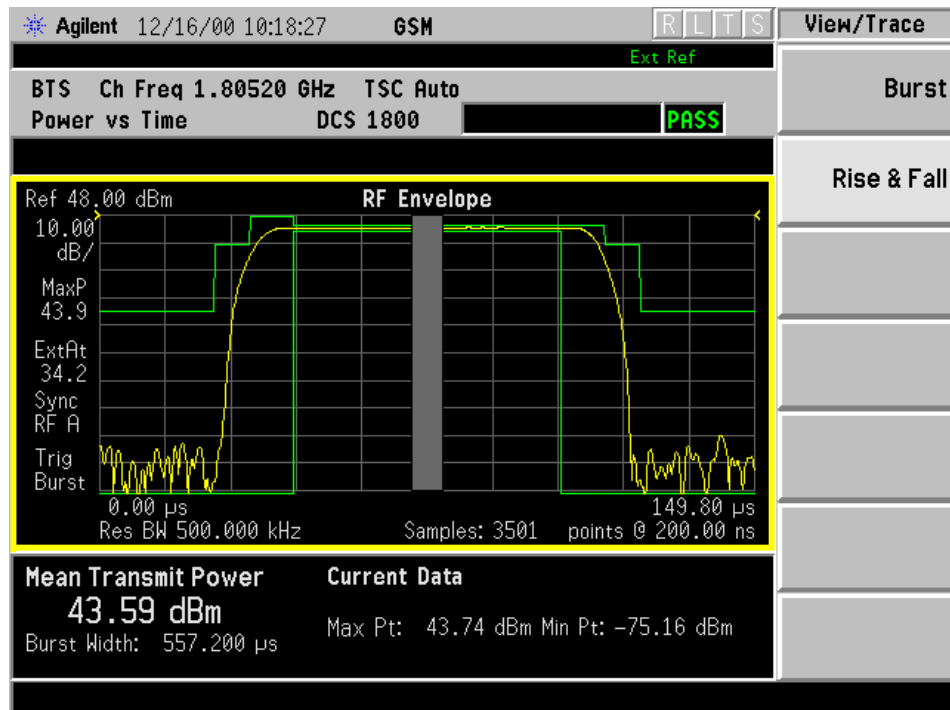



## Changing the Measurement Setup

**Table 3-7 Power vs. Time Measurement Defaults**

Measurement Parameter	Factory Default Condition
Avg Bursts	10 Off
Avg Mode	Exp
Avg Type	Pwr Avg (RMS)
Meas Time	1 Slot
Trig Source	RF Burst (Wideband)
Burst Sync	Training Seq
<b>Advanced</b>	
RBW Filter	Gaussian
Res BW	500.000 kHz

---

**NOTE** Parameters that are under the **Advanced** key seldom need to be changed. Any changes from the default values may result in invalid measurement data.

---

Make sure the Power vs. Time measurement is selected under the **Measure** menu. The **Meas Setup** key will access a menu which allows you to modify the averaging, trigger source, and burst sync for this measurement (as described in the “[Measurement Setup](#)” section at the beginning of this chapter). In addition, the following power vs. time measurement parameters can be modified:

- **Meas Time** - allows you to measure more than one timeslot. Enter a value in integer increments of “slots” with a range of 1 to 50. The actual measure time in  $\mu\text{s}$  is set somewhat longer than the specified number of slots in order to view the complete burst.
- **Advanced** - accesses a menu to change the following parameters:
  - RBW Filter** - chooses the type of filter, either **Gaussian** or **Flat** (Flatop). Gaussian is the best choice when looking at the overall burst or the rising and falling edges, as it has excellent pulse response. If you want to precisely examine just the useful part of the burst, choose **Flat**.
  - Res BW** - sets the resolution bandwidth.

### Power vs. Time Custom Masks

For the Power vs. Time measurement, you can define a user configurable limit mask to apply to the measured burst. This feature can only be accessed via SCPI commands. Refer to the programming manual for further information.

## Changing the View

The **View/Trace** key will access a menu which allows you to select the desired view of the measurement from the following selections:

- **Burst** - views the entire sweep as specified by the meas time.
- **Rise & Fall** - zooms in on the rising and falling portions of the burst being tested.

---

NOTE

The limit test will still be performed on the entire burst, (viewed using the **Burst** menu), when **Rise & Fall** is selected.

---

## Changing the Display

The **Display** key will allow you to turn the limit mask on and off. This also disables the mask limit test, but still calculates the power in the useful part.

## Troubleshooting Hints

If a transmitter fails the Power vs. Time measurement this usually indicates a problem with the units output amplifier or leveling loop.

---

## Making the EDGE ORFS Measurement

### Purpose

The EDGE ORFS measurement is the GSM EDGE (with GSM) version of adjacent channel power (ACP). Either a single offset is measured with corresponding traces or up to 15 offsets are measured and a table is displayed.

The output RF spectrum measurements determine the spectral energy emitted into the adjacent channels. Excessive amounts of energy spilling into an adjacent frequency channel could interfere with signals being transmitted to other MS or BTS. The measurements are divided into two main groups: spectrum due to the 0.3 GMSK modulation and noise, and spectrum due to switching transients (burst ramping).

Since GSM is a TDMA format, RF power is being switched on and off depending on whether the actual burst is being transmitted. The switching of power causes spectral splatter at frequencies other than that being transmitted by the carrier. Fast transitions in the time domain causes switching transients that have high frequency content associated with them.

---

#### NOTE

The default output RF spectrum measurements do not perform tests at frequency offsets greater than 1800 kHz from the carrier.

---

### Measurement Method

In this measurement, the transmitter (source) is set to transmit a GSM frame at a given channel (frequency). The instrument acquires a time record at a particular offset from the channel being transmitted. The method of acquiring the time record is either a FFT/Inverse-FFT method, or a direct time domain (DTD) method, depending on the offset. These two methods and when they are used, will be described below. When the offset is zero, the instrument is said to be measuring the carrier. For a given offset frequency from the carrier, the transmitter must not exceed a certain power level relative to the carrier. The GSM specification defines the offsets and their maximum absolute and relative power levels.

The general steps in making the measurement are as follows:

- Acquire time record (using either FFT or DTD methods, described below)
- Synchronize for gating on the carrier - finds 50% and 90% portion of burst for Spectrum Due to Modulation portion of the test
- Measure power of the carrier
- Compare each offset power to reference to get relative power level

The method of acquiring the time record is dependent on accuracy and dynamic range. With no pre-ADC filter (infinite bandwidth), the entire IF bandwidth of the IF signal is hitting the analog to digital converter (ADC). The ADC gain is set based on the peak level at its input. The dynamic range (noise floor) of the ADC is dependent on the gain selected. For the type of signals being measured, the highest energy within the IF bandwidth is at the carrier. Therefore, the lowest dynamic range (highest noise floor) of the ADC occurs when the full energy of the carrier is input to the ADC.

All offsets measured using the FFT method are done with the instrument tuned such that the carrier is at the center of the IF bandwidth. Therefore, the dynamic range of the offsets measured using the FFT method is the same as that for the carrier. The dynamic range requirement generally increases as the offset frequency increases. If the dynamic range requirement exceeds what is available by FFT method, the direct time domain (DTD) method utilizing the pre-ADC filter is used.

The **Direct Time Break Freq** key setting is the first offset frequency which is measured using the DTD method. Its range is determined by assuring no aliasing occurs on FFT offsets and that the dynamic range requirements are met.

The FFT method acquires a wideband signal (1.55 MHz) in a flattop filter. An FFT is performed to get the spectrum of the GSM signal. The resolution bandwidth filter can now be applied mathematically to the spectrum at multiple offsets, with an inverse-FFT performed on the data which passes the filter. In this way, multiple offsets are acquired from one time record and LO setting. Since the resolution bandwidth filter is a mathematical formula, it can be any shape and size, and is perfect. The VSA uses the 5-pole synchronously tuned filter that the GSM standard specifies.

The primary disadvantage to the FFT method is that the acquisition must include the carrier. The high energy of the carrier causes the ADC to range down, thus lowering the dynamic range. At large offsets, the dynamic range requirement is very challenging so the direct time domain (DTD) method is used. The LO is tuned to the particular offset and the pre-ADC filter is used to reduce the carrier. This allows the ADC to range up, giving higher dynamic range. The disadvantage to this method is that each offset measured has its own time record acquisition and LO tune position, and this causes the measurement to slow down compared to FFT offsets. The 5-pole synchronously tuned filter is approximated by utilizing a digital Gaussian filter and setting its equivalent noise bandwidth to that of the 5-pole synchronously tuned filter. For these DTD offset frequencies, the filter has closer-to-ideal 5-pole behavior (< 1% tolerance) than does a 10% tolerance, 5-pole analog filter.

Regardless of how the time record is obtained for a particular offset, the power must be measured and compared to the reference power. There are two measurements being made for the test: output RF spectrum due to modulation and the output RF spectrum due to switching transients. The GSM standard specifies which offsets get which tests. In these two modes, the following conditions are met:

- In the output RF spectrum due to modulation measurement, the average value during at least 40 bits between bit 87 and 132 (approximately equivalent to the 50% to 90% portion of the burst, excluding midamble) is retained. The vertical lines mark the section of the burst over which the measurement is made. If multiple bursts are examined, an average of the average values is calculated. The relative power (difference between the average power of the burst at zero offset and the average power of the burst at the indicated offset) and the absolute power are displayed.
- In the output RF spectrum due to switching transients, the peak value of the burst is retained. If multiple bursts are examined, then the maximum of the peak values is retained. The relative power (difference between the peak power of the burst at zero offset and the peak power of the burst at the indicated offset) and the absolute power are displayed.

The GSM standard specifies the tests are run on specified offsets from the carrier. The instrument identifies this as single offset or multiple offset modes. The measurement made in these two modes is the same, except that the multiple offset mode automatically makes the measurement at all the specified offsets frequencies and lists the results in a table at the end of the measurement.

Figure 3-20 shows a single-offset (Examine) trace for an entire GSM frame with timeslots 0, 2, and 6 turned on and timeslots 1, 3, 4, 5, and 7 turned off. The vertical bars show the portion used to measure power due to modulation.

**Figure 3-20 GSM Frame in Single-Offset (Examine)**

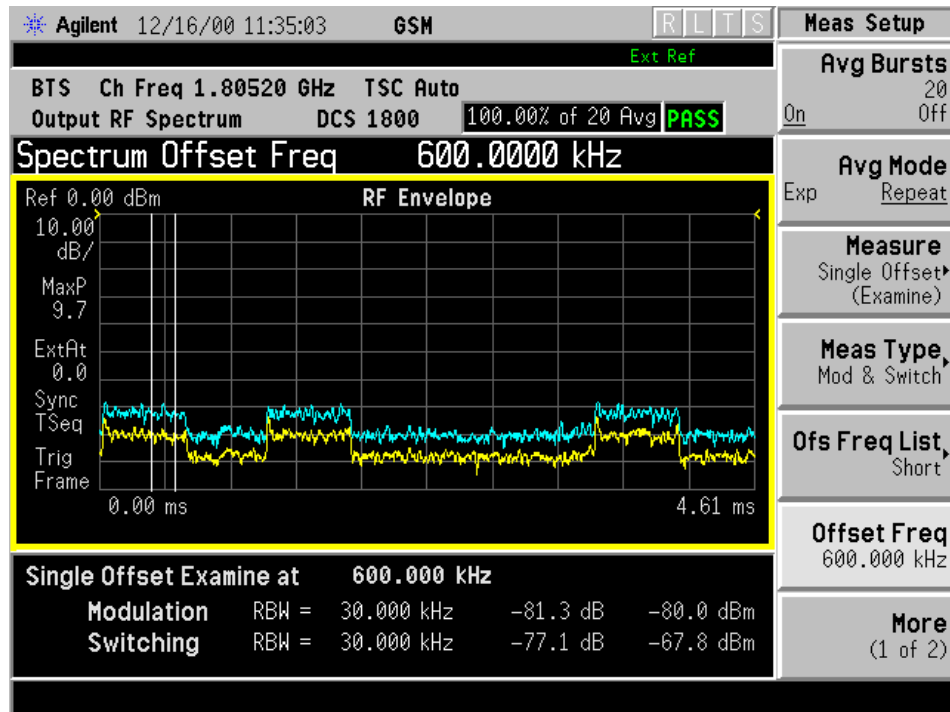

The RF envelope trace is displayed. If averaging is turned on, the trace is then averaged with previous traces. For the modulation measurement, the user may select the type of trace averaging, either log-power averaged (Video) or power averaged (RMS). For the switching transients measurement, the peak of the traces is used. For modulation, the displayed value is the average of points within the vertical bars. For transients, the displayed value is the max of all points for all traces (Max of Peak) over the entire frame.

## Making the Measurement

**NOTE**

The factory default settings provide a GSM compliant measurement. For special requirements, you may need to change some of the settings. Press **Meas Setup, More (1 of 2), Restore Meas Defaults** to return all parameters for the current measurement to their default settings.

Select the desired ARFCN, center frequency, timeslot, burst type, and TSC (Training Sequence Code) as described in the section titled [“Changing the Frequency Channel” on page 24](#).

When **Training Sequence** is selected as the burst sync for this measurement, set the **Timeslot** selection to determine which timeslot to measure. For example, if **Timeslot** is set to 2, the measurement will be made on the timeslot number 2. Be careful when adding delay in the **Trigger** setup, as this measurement does not take into account trigger delay when checking for a valid burst. If there is sufficient delay added (usually more than 25% of a timeslot), the burst might not be detected.

Press **Measure, Output RF Spectrum** to immediately make **Output RF Spectrum** the active measurement.

To change any of the measurement parameters from the factory default values, refer to the [“Changing the Measurement Setup”](#) section for this measurement.

## Results

**Figure 3-21**

**Output RF Spectrum Result (Short List) Modulation View**

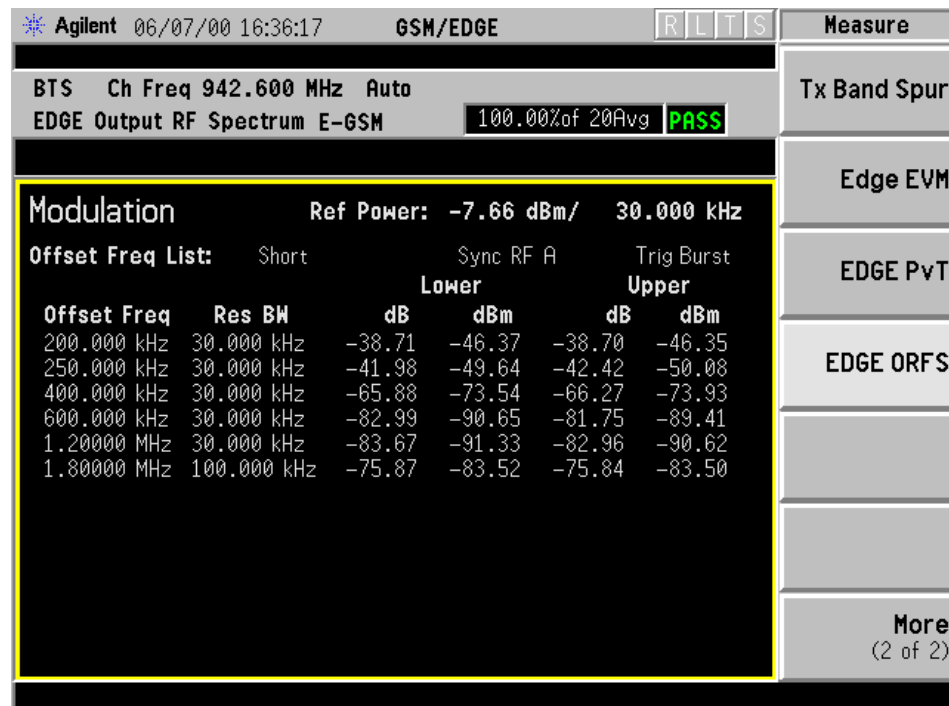

## Changing the Measurement Setup

**Table 3-8** Output RF Spectrum Measurement Defaults

Measurement Parameter	Factory Default Condition
Avg Bursts	20 On
Avg Mode	Repeat
Meas Method	Multi-Offset
Meas Type	Modulation
Ofs Freq List	Short
Offset Freq (when single offset is selected)	250.000 kHz
Trig Source	RF Burst
Burst Sync (information only)	RF Amptd
Fast Avg	On
<b>Advanced</b>	
Mod Avg	Log-Pwr Avg (Video)
Switching Avg (information only)	Max of Peak
Direct Time Break Freq	600.000 kHz
<b>Modulation Meas BWs</b>	
Carrier RBW	30.000 kHz
<1800 kHz Offset RBW	30.000 kHz
≥1800 kHz Offset RBW	100.000 kHz
VBW/RBW Ratio (information only)	1
<b>Switching Meas BWs</b>	
Carrier RBW	300.000 kHz
<1800 kHz Offset RBW	30.000 kHz
≥1800 kHz Offset RBW	30.000 kHz
VBW/RBW Ratio (information only)	3



NOTE

Parameters that are under the **Advanced** key seldom need to be changed. Any changes from the default values may result in invalid measurement data.

Make sure the Output RF SpectrumEDGE ORFS measurement is selected under the **Measure** menu. Press the **Meas Setup** key to access a menu which allows you to modify the averaging and trigger source for this measurement (as described in the “**Measurement Setup**” section at the beginning of this chapter). In addition, the following output RF spectrum measurement parameters can be modified:

- ❑ **Measure** - accesses a menu to choose the measurement mode.
  - Multi-Offset** - automatically makes measurements at all offset frequencies in the selected list (**Standard**, **Short**, or **Custom**). (See table below.) Press the **Ofs Freq List** key to select a list of offsets to measure.
  - Single Offset (Examine)** - makes a measurement at a single offset frequency as set by the **Offset Freq** softkey.
- ❑ **Meas Type** - accesses a menu to choose the measurement type.
  - Mod & Switch** - will perform both Modulation and Switching measurements.
  - Modulation** - measures the spectrum due to the 0.3 GMSK modulation and noise.
  - Switching** - measures the spectrum due to switching transients (burst ramping).
- ❑ **Ofs Freq List** - accesses a menu to choose the offset frequency list. Select a **Standard**, **Short**, or **Custom** list as shown in the table below.

<b>List</b>	<b>Modulation Offsets (kHz)</b>	<b>Switching Transients Offsets (kHz)</b>
<b>Standard</b>	100, 200, 250, 400, 600, 800, 1000, 1200, 1400, 1600, 1800, 3000, 6000	400, 600, 1200, 1800
<b>Short</b>	200, 250, 400, 600 1200, 1800	400, 600, 1200, 1800
<b>Custom</b>	User-defined list that specifies: Offset Freq, RES BW, Limit Offsets, Meas Type,  (currently settable only by remote commands)	

- ❑ **Offset Freq** - Only available when **Measure** is set to **Single Offset (Examine)**. The **Step** hardkeys (↑ or ↓) will step through the offset list as selected by the **Offs Freq List** key. Other offset frequencies can be entered using the RPG knob or the Data Entry keys.
- ❑ **Trig Source** - in this measurement, trigger source and burst sync are linked. Refer to the explanation under **Burst Sync**.
- ❑ **Burst Sync** - Synchronization is different on ORFS compared to other measurements. Since offsets may be very low power and acquired using very narrow filters, the burst edges are not well defined and there certainly is not enough information to perform a demodulation. Therefore all synchronization is performed on the carrier. The timing reference (“T0”) is then re-used on the offsets. Since “T0” on the carrier is determined with respect to the trigger point, the trigger point on the offsets is very important. Once “T0” is determined, the 50% and 90% points can be found.

Therefore, the trigger must be synchronous with respect to a rising edge of a burst. The RF Burst trigger will do this if the offset is within about 7 MHz of the carrier. Remember that since the RF Burst trigger is wideband, the carrier will still cause the signal to trigger. Assuming the trigger threshold remains constant, the trigger with respect to the burst will remain constant. Since the Frame Trigger uses an internal frame timer (clock), its period is set so that it occurs synchronously with respect to the transmitting frame. If an external trigger is used, it is important that it is synchronous with the burst.

Because of these requirements, only the trigger source can be selected while the measurement selects the burst sync type based on the trigger source.

<b>Trigger Source</b>	<b>Measurement Defined Burst Sync</b>
Free Run	None
RF Burst	RF Amplitude
Ext Front	External
Ext Rear	External
Frame	Training Sequence

---

**NOTE**

Video trigger source is not allowed, because when the instrument is tuned to offset frequencies away from the carrier, the video trigger threshold will not be reached (due to the low power level of the offset.)

---

- ❑ **Fast Avg** - Fast averaging is a technique developed by HP/Agilent. The GSM standard specifies 50% to 90% portion of the burst, excluding the midamble, be measured in 50 averages. Since most offsets are measured in a 30 kHz filter, there is a lot of variation from burst to burst, hence the averaging.

The fast average method makes use of the 10% to 90% portion of the burst, excluding the midamble. The 10% to 50% portion of the burst has statistically the same average power as the 50% to 90%. Therefore, measuring both portions from one burst is statistically the same as measuring 50% to 90% from two bursts. Now, two averages are completed with one burst. When averaging is turned on, this will double the speed of the measurement.

This method is only applicable on the modulation portion of the test, and only when averaging is enabled. The method is not available when Modulation and Switching are done at the same time.

- ❑ **Advanced** - accesses a menu with the following keys:
  - **Mod Avg** - choose between:
    - Pwr Avg (RMS)**
    - Log-Pwr Avg (Video)**
  - **Switching Avg** - information only. Averaging is fixed at maximum of peak.
  - **Modulation Meas BWs** - accesses a menu with the following selections:
    - Carrier RBW**
    - <1800 kHz Offset RBW**
    - >=1800 kHz Offset RBW**
    - VBW/RBW Ratio** - information only. Modulation ratio is fixed at 1.
  - **Switching Meas BWs** - accesses a menu with the following selections:
    - Carrier RBW**
    - <1800 kHz Offset RBW**
    - >=1800 kHz Offset RBW**
    - VBW/RBW Ratio** - information only. Switching ratio is fixed at 3.

- **Direct Time Break Freq** - Selects the transition frequency (the first offset frequency) where the Direct Time Domain method is used instead of the FFT method. The Direct Time Domain offers a high dynamic range and is faster for measuring at a few offset frequencies. The FFT method has a moderate dynamic range (generally sufficient when the RBW = 30 kHz). It is much faster for measuring at many offset frequencies

## Changing the View

If the Multi-Offset measurement has been chosen and the Meas Type is Mod & Switch, pressing the **View/Trace** key will allow you to select the desired view of the current measurement. If the Meas Type is Modulation, the **Switching Numeric** view is unavailable. If the Meas Type is Switching, the **Modulation Numeric** view is unavailable.

If the Single Offset measurement has been chosen, the **Modulation Numeric** and the **Switching Numeric** softkeys are unavailable (grayed out) as both modulation and switching results are always displayed.

## Troubleshooting Hints

The Output RF Spectrum measurement, along with the Phase and Frequency Error measurement, can reveal numerous faults in the transmit chain, such as the I/Q baseband generator, filters & modulator.